



Cisco Aironet 17-dBi Sector Antenna (AIR-ANT5117S-N)

This document outlines the specifications, description, and mounting and alignment instructions for the Cisco Aironet 5-GHz 17-dBi Sector Antenna (AIR-ANT5117S-N). The antenna operates in the 5-GHz frequency range and is designed for use in point-to-multipoint environments. The antenna is designed to be used outdoors and can be mounted on 1.5 in. to 3.5 in. (3.8 to 8.9 cm) diameter masts.

The following information is provided in this document.

- [Technical Specifications, page 2](#)
- [System Requirements, page 4](#)
- [Safety Precautions, page 4](#)
- [Installation Notes, page 5](#)
- [Obtaining Documentation, Obtaining Support, and Security Guidelines, page 12](#)



Americas Headquarters:
Cisco Systems, Inc., 170 West Tasman Drive, San Jose, CA 95134-1706 USA

© 2007 Cisco Systems, Inc. All rights reserved.

Technical Specifications

Antenna type	90-degree sector
Operating frequency range	4900 – 5850 MHz
Nominal input impedance	50
2:1 VSWR bandwidth	4900 – 5850 MHz
Gain (dBi)	16.5
Polarization	Vertical
Azimuth plane 3-dB beamwidth	90 degrees
Elevation plane 3-dB beamwidth	5.5 degrees
Length	24.7 in. (62.74 cm)
Width	2.75 in. (7 cm)
Depth	1-7/8 in. (4.76 cm)
Weight	2 lbs (0.9 kg)
Connector type	Standard N-female
Operating temperature	-40 - 185 F (-40 - 85 C)
Wind rating	125 mph (201 kmh)

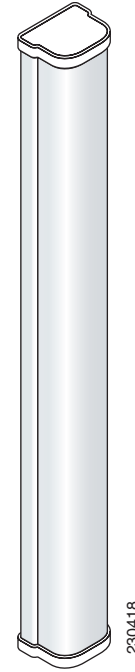

Azimuth Radiation Pattern

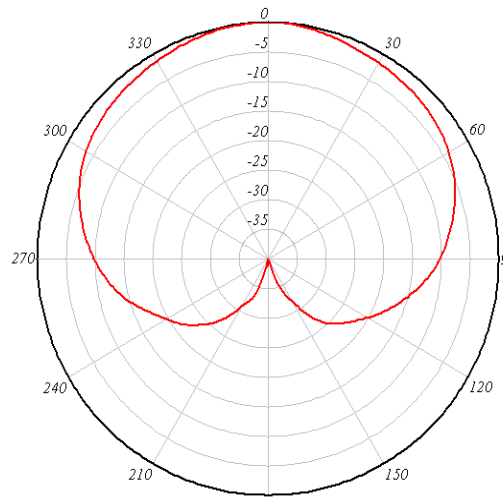

Elevation Radiation Pattern

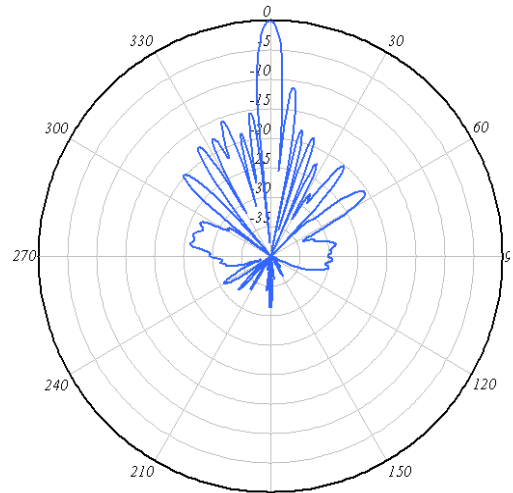

The following table indicates the minimum required attenuation between the access point radio and the antenna when using the lowest RF power setting. Using a higher RF power setting will require additional attenuation (for a given antenna).

The attenuation can be in the form of an attenuator, coax cable loss, or both. This attenuation is required in order for the system to meet the regulatory requirements of the indicated country. Failure to install the minimum amount of attenuation results in non-compliant operation. Table 1 displays the required attenuation.



Note X indicates that the antenna is not authorized to be used in that country.

Table 1 Required Attenuation in dB

	2.4 GHz Antennas (802.11 B /G)			5 GHz Antennas (802.11 A)		
	AIR-ANT2480V-N 2.4 GHz 8 dBi Omni	AIR-ANT2410Y-R 2.4 GHz 10 dBi Yagi	AIR-ANT2414S-R 2.4 GHz 14 dBi Sector	AIR-ANT58G10SSA-N 5 GHz 9.5 dBi Sector	AIR-ANT5114P-N 4.9–5.8 GHz 14 dBi Patch	AIR-ANT5117S-N 4.9–5.8 GHz 17 dBi Sector
Asia						
Australia	None	None	None	None	-1	-4
China	None	None	None	None	-1	-4
Hong Kong	None	None	None	None	-1	-4
India	None	None	None	X	X	X
Japan	None	X	X	X	X	X
Korea	X	X	X	X	X	X
New Zealand	None	None	None	None	-1	-4
Singapore	None	-1	-5	None	-1	-4
Taiwan	None	X	X	None	X	X
Thailand	None	-1	-5	X	X	X
EU						
Belgium	None	-1	-5	None	-2	-5
Denmark	None	-1	-5	None	-2	-5
Finland	None	-1	-5	None	-2	-5
France	None	-1	-5	None	-2	-5
Germany	None	-1	-5	None	-2	-5
Italy	None	-1	-5	None	-2	-5
Netherlands	None	-1	-5	None	-2	-5
Norway	None	-1	-5	None	-2	-5
Spain	None	-1	-5	None	-2	-5

Table 1 Required Attenuation in dB (continued)

	2.4 GHz Antennas (802.11 B /G)			5 GHz Antennas (802.11 A)		
	AIR-ANT2480V-N 2.4 GHz 8 dBi Omni	AIR-ANT2410Y-R 2.4 GHz 10 dBi Yagi	AIR-ANT2414S-R 2.4 GHz 14 dBi Sector	AIR-ANT58G10SSA-N 5 GHz 9.5 dBi Sector	AIR-ANT5114P-N 4.9–5.8 GHz 14 dBi Patch	AIR-ANT5117S-N 4.9–5.8 GHz 17 dBi Sector
Sweden	None	-1	-5	None	-2	-5
Switzerland	None	-1	-5	None	-2	-5
United Kingdom	None	-1	-5	None	-2	-5
North America						
United States	None	X	X	None	None	None
Canada	None	X	X	None	None	None
Mexico	None	None	None	None	-1	-4
South America						
Brazil	None	None	None	None	-1	-4

System Requirements

This antenna is designed for use with the Cisco 5-GHz bridges and access points using a standard N-connector.

Safety Precautions



Warning

Installation of this antenna near power lines is dangerous. For your safety, follow the installation directions.

Each year hundreds of people are killed or injured when attempting to install an antenna. In many of these cases, the victim was aware of the danger of electrocution but did not take adequate steps to avoid the hazard.

For your safety, and to help you achieve a good installation, please read and follow these safety precautions. **They may save your life!**

1. If you are installing an antenna for the first time, for your own safety as well as others, seek professional assistance. Your Cisco sales representative can explain which mounting method to use for the size and type antenna you are about to install.
2. Select your installation site with safety, as well as performance in mind. Remember: electric power lines and phone lines look alike. For your safety, assume that any overhead line can kill you.
3. Call your electric power company. Tell them your plans and ask them to come look at your proposed installation. This is a small inconvenience considering your life is at stake.

4. Plan your installation carefully and completely before you begin. Successful raising of a mast or tower is largely a matter of coordination. Each person should be assigned to a specific task, and should know what to do and when to do it. One person should be in charge of the operation to issue instructions and watch for signs of trouble.
5. When installing your antenna, remember:
 - a. **Do not** use a metal ladder.
 - b. **Do not** work on a wet or windy day.
 - c. **Do** dress properly—shoes with rubber soles and heels, rubber gloves, long sleeved shirt or jacket.
6. If the assembly starts to drop, get away from it and let it fall. Remember, the antenna, mast, cable, and metal guy wires are all excellent conductors of electrical current. Even the slightest touch of any of these parts to a power line completes an electrical path through the antenna and the installer: **You!**
7. If any part of the antenna system should come in contact with a power line, **don't touch it or try to remove it yourself. Call your local power company.** They will remove it safely.
8. If an accident should occur with the power lines call for qualified emergency help immediately.

Installation Notes

The antenna is designed to be mounted on a mast but can be mounted on most flat vertical surfaces. If you mount the antenna on a vertical surface using the mounting hardware provided, you can adjust the antenna's elevation but not its azimuth. Therefore, the surface on which you mount the antenna must be oriented in the direction of the bridge link.

Choosing a Mounting Location

The antenna is designed to create a directional broadcast pattern. To achieve this pattern, mount the antenna clear of any obstructions to the sides of the radiating element. If the mounting location is on the side of a building or tower, the antenna pattern is degraded on the building or tower side.

Site Selection

Before attempting to install your antenna, determine where you can best place the antenna for safety and performance.

Follow these steps to determine a safe distance from wires, power lines, and trees.

-
- Step 1** Measure the height of your antenna.
- Step 2** Add the height to the length of your tower or mast and then double this total for the minimum recommended safe distance.



Caution

If you are unable to maintain this safe distance, stop and get professional help.

Generally, the higher an antenna is above the ground, the better it performs. Good practice is to install your antenna about 5 to 10 ft (1.5 to 3 m) above the roof line and away from all power lines and obstructions. If possible, find a mounting place directly above your wireless device so that the lead-in cable can be as short as possible.

Hardware, Tools, and Fasteners Required

A mast mounting installation kit is shipped with the antenna and consists of the following hardware.

- Upper bracket (adjustable) (1)
- Lower bracket (fixed) (1)
- Swing Arm (2)
- Clamp (2)
- 1/4 in. - 20 x 5 in. Hex Head Bolt (4)
- 1/4 in. - 20 x 3/4 in. Hex Head Bolt (6)
- 1/4 in. Flat Washer (18)
- 1/4 in. Lock Washer (14)
- 1/4 in. - 20 Hex Nut (8)

You will need two 7/16 in. deep well sockets or wrenches to install the antenna.

Installation Process

The following sections contains typical procedures for installing the antenna on a mast. Your installation may vary. The process consists of the following procedures.

- [Attaching the Mounting Brackets to the Pole](#) (Figure 1)
- [Mounting the Antenna to Pole Brackets](#) (Figure 2)
- [Aligning the Antenna](#) (Figure 3)
- [Attaching the Cable](#) (Figure 4)
- [Grounding the Antenna](#)

Before you begin, refer to [Figure 1](#), [Figure 2](#), [Figure 3](#), and [Figure 4](#) to become familiar with the entire installation process.

Attaching the Mounting Brackets to the Pole

Two mounting brackets are provided; one is adjustable and the other is not. The attachment process is the similar for both brackets. Follow these steps to attach the mounting brackets to the pole. Refer to [Figure 1](#) for a visual display of the attachment process.

-
- Step 1** Attach the upper bracket and clamp to the pole using two 1/4 in. - 20 x 5 in. hex head bolts. Attach each bolt using a 1/4 in. flat washer, a 1/4 in. lock washer, and a 1/4 in. - 20 hex nut. See [Figure 1](#).
- Step 2** Attach a swing arm to each side of the upper bracket using a 1/4 in. -20 x 3/4 in. hex head bolt. Attach the bolt using a 1/4 in. flat washer, a 1/4 in. lock washer, and a 1/4 in. -20 hex nut. See [Figure 1](#).

- Step 3** Attach the lower bracket and clamp using the same method as the upper bracket and clamp. See Step 1 for more information. The lower bracket does not require a swing arm.

Figure 1 Attaching Mounting Brackets to Pole

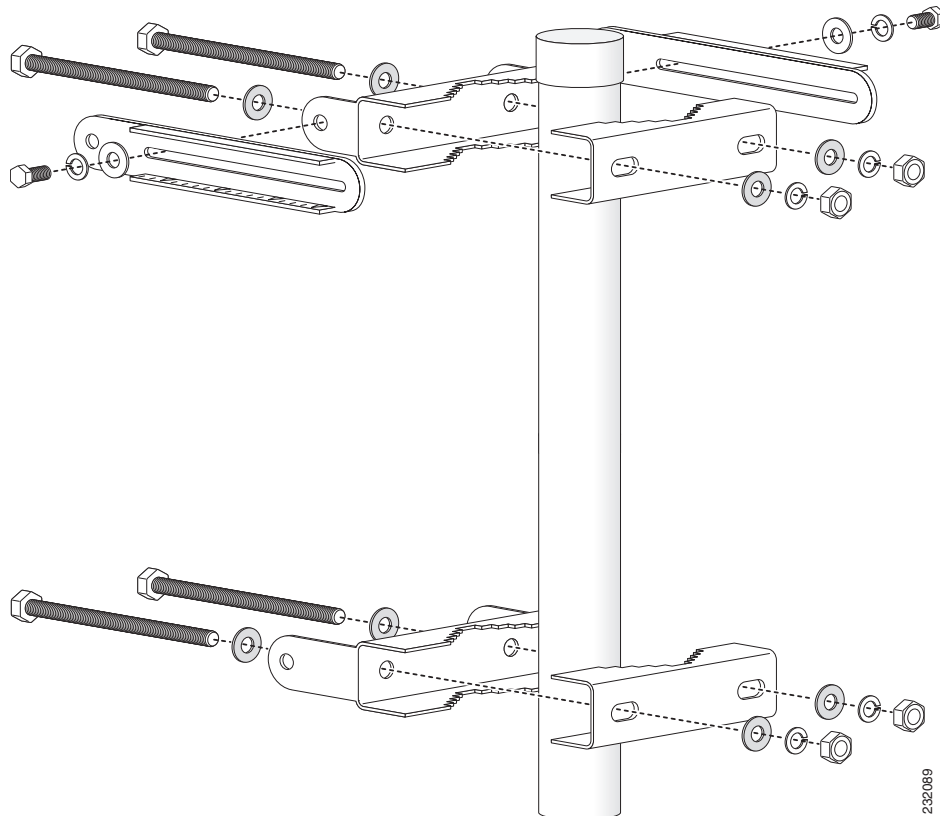

Mounting the Antenna to Pole Brackets

The antenna has studs onto which you attach the antenna brackets. The top antenna bracket attaches to the adjustable pole bracket (with the swing arm) at the top of the pole.

Follow these steps to attach the antenna to the antenna brackets and to the assembled pole brackets (See Figure 2):

- Step 1** Position the antenna so that the arrow on the orientation label is pointed up. The arrow points to the top of the antenna so that it can be installed correctly.



Note The orientation label is located on the back panel of the antenna.

- Step 2** Attach the antenna brackets to the top and bottom set of studs located on the antenna. Attach the brackets using a 1/4 in. flat washer, a 1/4 in. lock washer, and a 1/4 in. - 20 hex nut. Use a 7/16 in. socket or wrench to tighten the nuts. Do not overtighten (torque 5.4 to 5.9 nm).

Step 3 Attach the top antenna bracket to the adjustable pole bracket located at the top of the pole. With an appropriate socket or wrench, attach the antenna bracket using a 1/4 in. - 20 x 3/4 in. hex head bolt, a 1/4 in. flat washer, a 1/4 in. lock washer, and a 1/4 in.- 20 hex nut on each side of the bracket.

- a. Use a 7/16 in. socket or wrench to capture the hex head bolt while you tighten the nuts.
- b. Do not completely tighten the nuts (torque the bolts to 7.6 to 8.1 nm).

See [Figure 2](#) for a visual display of this process.

Figure 2 Mounting Antenna Brackets to Pole Brackets

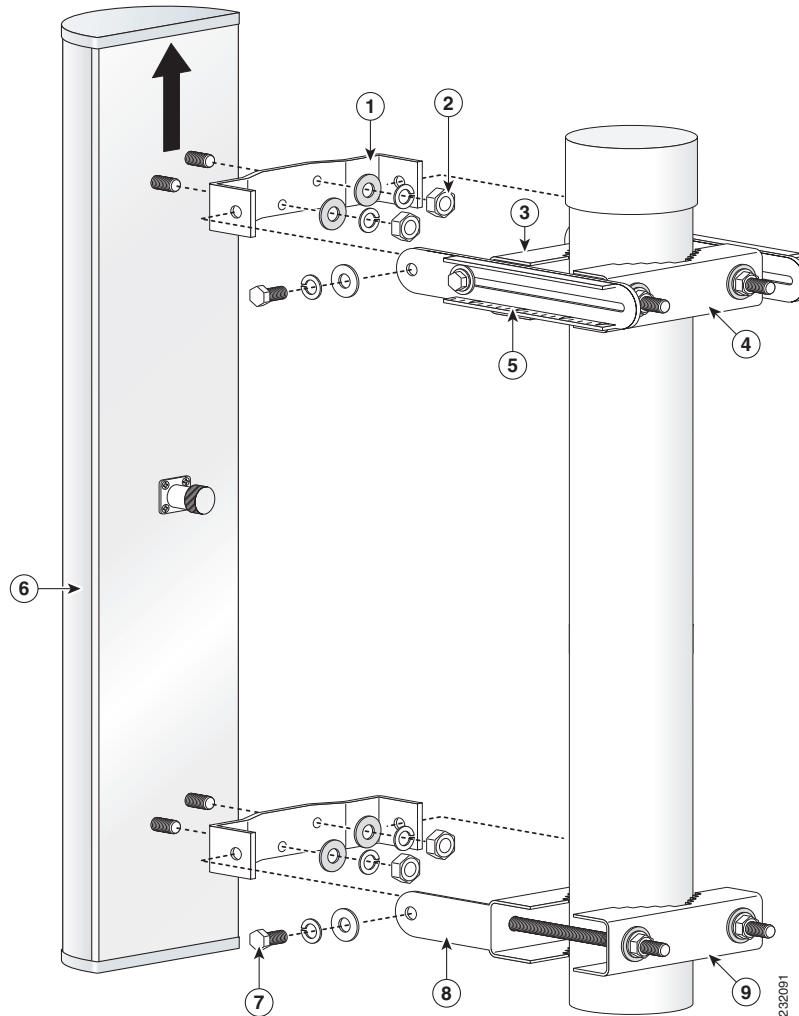

1	Antenna bracket	6	Antenna
2	1/4-20 nut, flat and lock washer (torque 5.4 to 5.9 nm)	7	1/4-20 bolt, flat washer, and lock washer
3	Upper Bracket	8	Lower bracket
4	Clamp	9	Clamp
5	Swing arm		

Aligning the Antenna

Align the antenna to Azimuth direction and the desired elevation angle. See [Figure 3](#).

Figure 3 *Adjusting the Azimuth and Elevation*

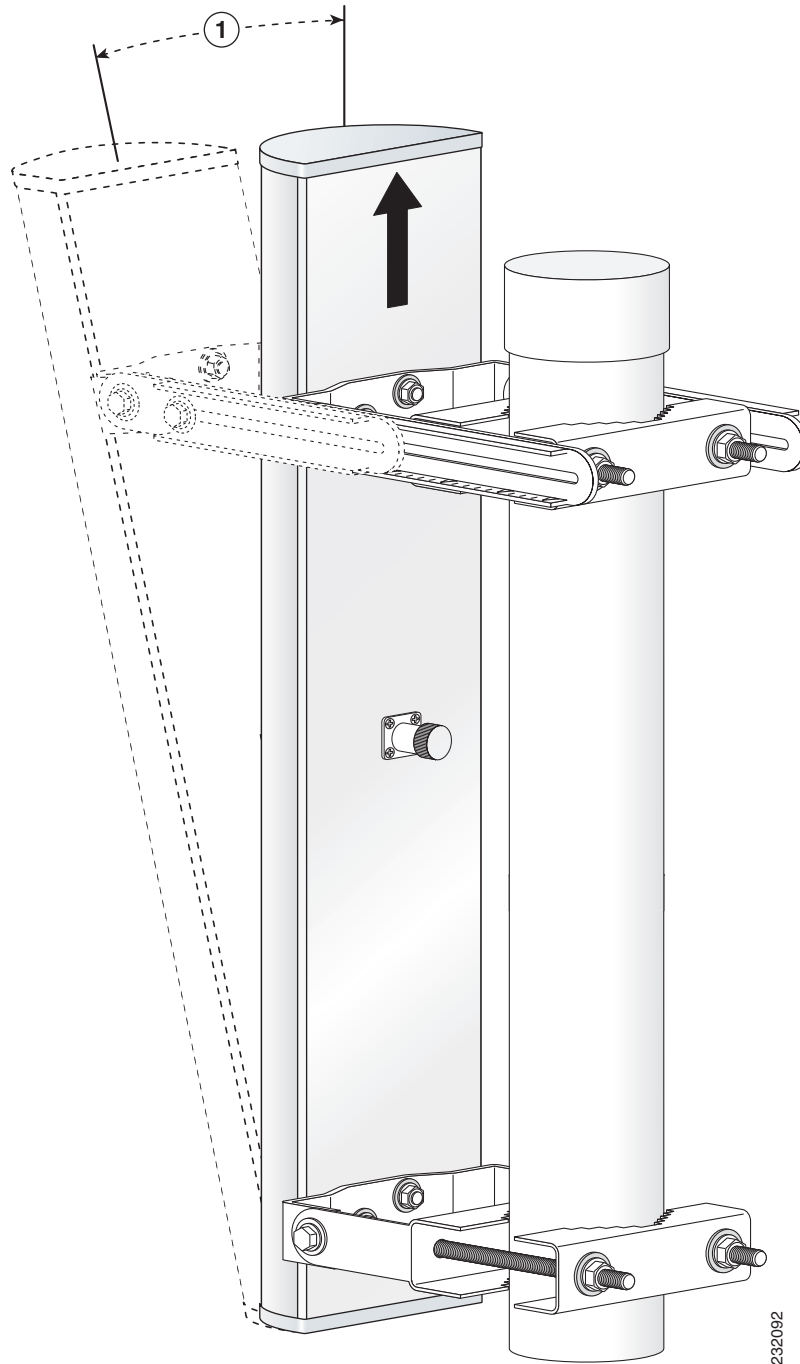

1 Elevation Adjustment Range—0 to 15 degrees.

Attaching the Cable

Attach the appropriate cable to the antenna. Torque the N-Connector to 0.9 +/- 0.15 nm. See [Figure 4](#).



Note

Cisco recommends a high-quality, low-loss cable for use with the antenna. See [Suggested Cable](#) for more information.

Figure 4 Attaching the Cable

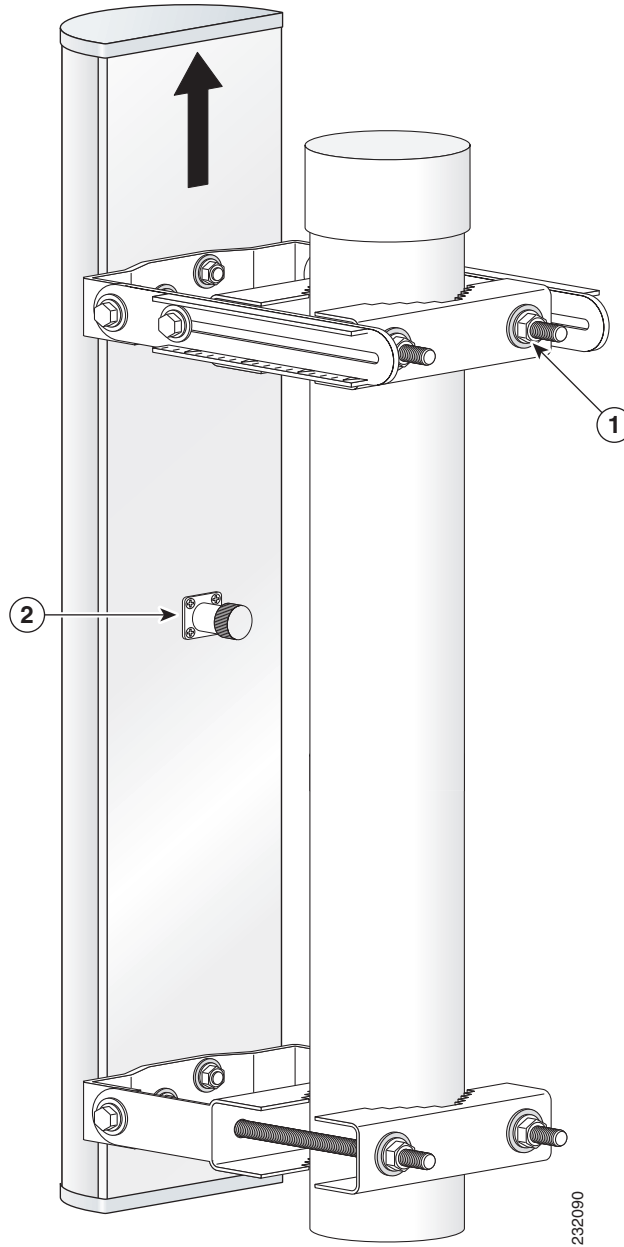

1	Bolts to tighten antenna clamps.	2	N-Connector for the cable.
----------	----------------------------------	----------	----------------------------

Grounding the Antenna

Follow these steps to ground the antenna in accordance with national electrical code instructions.

-
- Step 1** Use no. 10 AWG copper or no. 8 or larger copper-clad steel or bronze wire as ground wires for both mast and lead-in. Securely clamp the wire to the bottom of the mast.
 - Step 2** Secure the lead-in wire to an antenna discharge unit and the mast ground wire to the building with stand-off insulators spaced from 4 to 8 ft. (1.2 to 2.4 m) apart.
 - Step 3** Mount the antenna discharge unit as closely as possible to where the lead-in wire enters the building.
 - Step 4** Drill a hole in the building's wall as closely as possible to the equipment to which you will connect the lead-in cable.



Warning

There may be wires in the wall. Make sure your drilling location is clear of any obstructions or other hazards.

- Step 5** Pull the cable through the hole and form a drip loop close to where it enters the building.
 - Step 6** Thoroughly waterproof the lead-in area.
 - Step 7** Install a lightning arrester.
 - Step 8** Connect the lead-in cable to the equipment.
-

Suggested Cable

Cisco recommends a high-quality, low-loss cable for use with the antenna.



Note

Coaxial cable loses efficiency as the frequency increases, resulting in signal loss. The cable should be kept as short as possible because cable length also determines the amount of signal loss (the longer the run, the greater the loss).

The mating connector to the antenna is an appropriate n-type jack. The connector on the opposite end will vary according to the type of equipment used.

After the cable is attached to the antenna, make sure that the connections are sealed (if outdoors) to prevent moisture and other weathering elements from affecting performance. Cisco recommends using a coax seal (such as CoaxSeal) for outdoor connections. Silicon sealant or electrical tape are **not** recommended for sealing outdoor connections.

Obtaining Documentation, Obtaining Support, and Security Guidelines

For information on obtaining documentation, obtaining support, providing documentation feedback, security guidelines, and also recommended aliases and general Cisco documents, see the monthly *What's New* in Cisco Product Documentation, which also lists all new and revised Cisco technical documentation, at:

<http://www.cisco.com/en/US/docs/general/whatsnew/whatsnew.html>

CCVP, the Cisco logo, and the Cisco Square Bridge logo are trademarks of Cisco Systems, Inc.; Changing the Way We Work, Live, Play, and Learn is a service mark of Cisco Systems, Inc.; and Access Registrar, Aironet, BPX, Catalyst, CCDA, CCDP, CCIE, CCIP, CCNA, CCNP, CCSP, Cisco, the Cisco Certified Internetwork Expert logo, Cisco IOS, Cisco Press, Cisco Systems, Cisco Systems Capital, the Cisco Systems logo, Cisco Unity, Enterprise/Solver, EtherChannel, EtherFast, EtherSwitch, Fast Step, Follow Me Browsing, FormShare, GigaDrive, HomeLink, Internet Quotient, IOS, iPhone, IP/TV, iQ Expertise, the iQ logo, iQ Net Readiness Scorecard, iQuick Study, LightStream, Linksys, MeetingPlace, MGX, Networking Academy, Network Registrar, PIX, ProConnect, ScriptShare, SMARTnet, StackWise, The Fastest Way to Increase Your Internet Quotient, and TransPath are registered trademarks of Cisco Systems, Inc. and/or its affiliates in the United States and certain other countries.

All other trademarks mentioned in this document or Website are the property of their respective owners. The use of the word partner does not imply a partnership relationship between Cisco and any other company. (0709R)