



Cisco ASA 5506-X, ASA 5506W-X, and ASA 5506H-X Hardware Installation Guide

First Published: April 07, 2015

Last Modified: April 06, 2016

Americas Headquarters

Cisco Systems, Inc.
170 West Tasman Drive
San Jose, CA 95134-1706
USA
<http://www.cisco.com>
Tel: 408 526-4000
800 553-NETS (6387)
Fax: 408 527-0883

Text Part Number: Online Only

THE SPECIFICATIONS AND INFORMATION REGARDING THE PRODUCTS IN THIS MANUAL ARE SUBJECT TO CHANGE WITHOUT NOTICE. ALL STATEMENTS, INFORMATION, AND RECOMMENDATIONS IN THIS MANUAL ARE BELIEVED TO BE ACCURATE BUT ARE PRESENTED WITHOUT WARRANTY OF ANY KIND, EXPRESS OR IMPLIED. USERS MUST TAKE FULL RESPONSIBILITY FOR THEIR APPLICATION OF ANY PRODUCTS.

THE SOFTWARE LICENSE AND LIMITED WARRANTY FOR THE ACCOMPANYING PRODUCT ARE SET FORTH IN THE INFORMATION PACKET THAT SHIPPED WITH THE PRODUCT AND ARE INCORPORATED HEREIN BY THIS REFERENCE. IF YOU ARE UNABLE TO LOCATE THE SOFTWARE LICENSE OR LIMITED WARRANTY, CONTACT YOUR CISCO REPRESENTATIVE FOR A COPY.

The Cisco implementation of TCP header compression is an adaptation of a program developed by the University of California, Berkeley (UCB) as part of UCB's public domain version of the UNIX operating system. All rights reserved. Copyright © 1981, Regents of the University of California.

NOTWITHSTANDING ANY OTHER WARRANTY HEREIN, ALL DOCUMENT FILES AND SOFTWARE OF THESE SUPPLIERS ARE PROVIDED "AS IS" WITH ALL FAULTS. CISCO AND THE ABOVE-NAMED SUPPLIERS DISCLAIM ALL WARRANTIES, EXPRESSED OR IMPLIED, INCLUDING, WITHOUT LIMITATION, THOSE OF MERCHANTABILITY, FITNESS FOR A PARTICULAR PURPOSE AND NONINFRINGEMENT OR ARISING FROM A COURSE OF DEALING, USAGE, OR TRADE PRACTICE.

IN NO EVENT SHALL CISCO OR ITS SUPPLIERS BE LIABLE FOR ANY INDIRECT, SPECIAL, CONSEQUENTIAL, OR INCIDENTAL DAMAGES, INCLUDING, WITHOUT LIMITATION, LOST PROFITS OR LOSS OR DAMAGE TO DATA ARISING OUT OF THE USE OR INABILITY TO USE THIS MANUAL, EVEN IF CISCO OR ITS SUPPLIERS HAVE BEEN ADVISED OF THE POSSIBILITY OF SUCH DAMAGES.

Any Internet Protocol (IP) addresses and phone numbers used in this document are not intended to be actual addresses and phone numbers. Any examples, command display output, network topology diagrams, and other figures included in the document are shown for illustrative purposes only. Any use of actual IP addresses or phone numbers in illustrative content is unintentional and coincidental.

Cisco and the Cisco logo are trademarks or registered trademarks of Cisco and/or its affiliates in the U.S. and other countries. To view a list of Cisco trademarks, go to this URL: <http://www.cisco.com/go/trademarks>. Third-party trademarks mentioned are the property of their respective owners. The use of the word partner does not imply a partnership relationship between Cisco and any other company. (1110R)

© 2015 Cisco Systems, Inc. All rights reserved.



CONTENTS

CHAPTER 1

About the ASA 5506-X, ASA 5506W-X, and ASA 5506H-X 1

About the ASA 5506-X, ASA 5506W-X, and ASA 5506H-X 1

Package Contents 4

Front Panel 5

Rear Panel 5

Status Lights 8

Network Ports 10

Console Ports 10

Internal and External Flash Storage 11

Solid State Drive 11

Power Supply Modules 12

Hardware Specifications 12

Power Cord Specifications 13

CHAPTER 2

Prepare for Installation 23

Installation Warnings 23

Position the ASA 24

Mount and Deployment Preparation for the ASA 5506W-X 25

Safety Recommendations 25

Maintain Safety with Electricity 25

Prevent Electrostatic Discharge Damage 26

Site Environment 26

Site Considerations 27

Power Supply Considerations 27

Equipment Rack Configuration Considerations 27

CHAPTER 3

Mount and Connect the ASA 29

Desktop Mount the ASA 29

- Wall Mount the ASA 30
- Rack Mount the ASA 32
- Install the ASA 5506H-X in a DIN Rail 34
- Connect Cables, Turn on Power, and Verify Connectivity 37
- Connect to a Console Terminal or PC 39
 - Connect to the Console Port with Microsoft Windows 39
 - Connect to the Console Port with Mac OS X 42
 - Connect to the Console Port with Linux 43



About the ASA 5506-X, ASA 5506W-X, and ASA 5506H-X

This chapter describes the hardware features of the ASA 5506-X series, and contains the following sections:

- [About the ASA 5506-X, ASA 5506W-X, and ASA 5506H-X, page 1](#)
- [Package Contents, page 4](#)
- [Front Panel, page 5](#)
- [Rear Panel, page 5](#)
- [Status Lights, page 8](#)
- [Network Ports, page 10](#)
- [Console Ports, page 10](#)
- [Internal and External Flash Storage, page 11](#)
- [Solid State Drive, page 11](#)
- [Power Supply Modules, page 12](#)
- [Hardware Specifications, page 12](#)
- [Power Cord Specifications, page 13](#)

About the ASA 5506-X, ASA 5506W-X, and ASA 5506H-X

The Cisco ASA 5506-X, ASA 5506W-X, and ASA 5506H-X adaptive security appliances are part of the ASA 5500-X of next-generation mid-range ASAs and are built on the same security platform as the rest of the ASA family.

This next-generation ASA delivers unprecedented levels of defense against threats to the network with deeper web inspection and flow-specific analysis, improved secure connectivity via end-point security posture validation, and voice and video over VPN support. It also provides enhanced support for intelligent information networks through improved network integration, resiliency, and scalability.

This ASA is a smaller form-factor chassis, intended primarily for desktop or wall-mounting, although one or two can be mounted in a single rack shelf. The ASA has a standard 1 RU chassis. See [Cisco ASA 5500-X Series Next-Generation Firewalls](#) to compare the performance metrics and capabilities of the 5500-X ASAs.

**Caution**

Do not stack the ASA chassis on top of another ASA chassis. If you stack the units, they will overheat, which causes the units to power cycle.

ASA 5506W-X Wireless Features

The ASA 5506W-X supports two high-performing spatial stream rates over a deployable distance with high reliability when serving clients. The ASA 5506W-X contains two simultaneous dual-band radios (2.4-GHz and 5-GHz 802.11n MIMO radios) in a controller-based mode or autonomous mode. It has integrated internal antennas that support full inter-operability with leading 802.11n clients. The radio hardware supports Unified, FlexConnect, and Monitor-mode.

The ASA 5506W-X has the following processor features:

- 128 MB NAND flash size
- 1 MB NOR flash size
- 128 MB DDR2 memory bus, x32

The 2.4 GHz and 5 GHz 802.11n radios have the following features:

- 802.11n standard compliant
- A-MPDU TX
- HT Duplicate Mode
- 2TX x 2RX
- 2-spatial streams, 300 Mbps PHY rate
- Maximal ratio combining (MRC)
- Cyclic Shift Diversity (CSD)
- MCS0-MCS15; Short or Long Guard Intervals
- DFS for UNII-2 and UNII-2 Extended channels, including 0.5us radar pulse detection

The ASA 5506W-X is configured with four single-band, inverted-F antennas (two 2.4-GHz and two 5-GHz), which are evenly spaced inside the top of the chassis. Peak gains are approximately 3 dBi in the 2.4-GHz band and 5 dBi in the 5-GHz band.

ASA 5506H-X Features

The ASA 5506H-X is a hardened version of the 5506-X with a ruggedized chassis, power supply, SSD, and four ports instead of eight. It is ruggedized because it supports a much wider industrial operational temperature range (-20C to 60C), meets the harsh EMI and environmental criteria for the IEC1613 and IEC 61850-3 power substation standards, and meets IEC60529 IP40 for ingress protection.

**Note**

Before beginning any of the procedures described in this book, be sure to read the [Regulatory Compliance and Safety Information](#) for the Cisco ASA 5506-X series and follow proper safety procedures.

Package Contents

The following figure shows the package contents for the ASA 5506-X and ASA 5506W-X. Note that the contents are subject to change and your exact contents might contain additional or fewer items.

Figure 1: ASA 5506-X and 5506W-X Package Contents

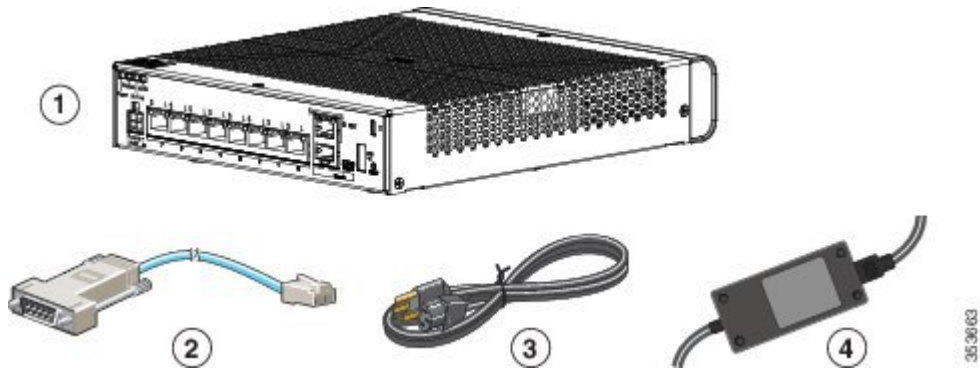

1	Chassis	2	Blue Console Cable PC Terminal Adapter
3	Power cord	4	Brick power supply

The following figure shows the package contents for the ASA 5506H-X. Note that the contents are subject to change and your exact contents might contain additional or fewer items.

Figure 2: ASA 5506H-X Package Contents

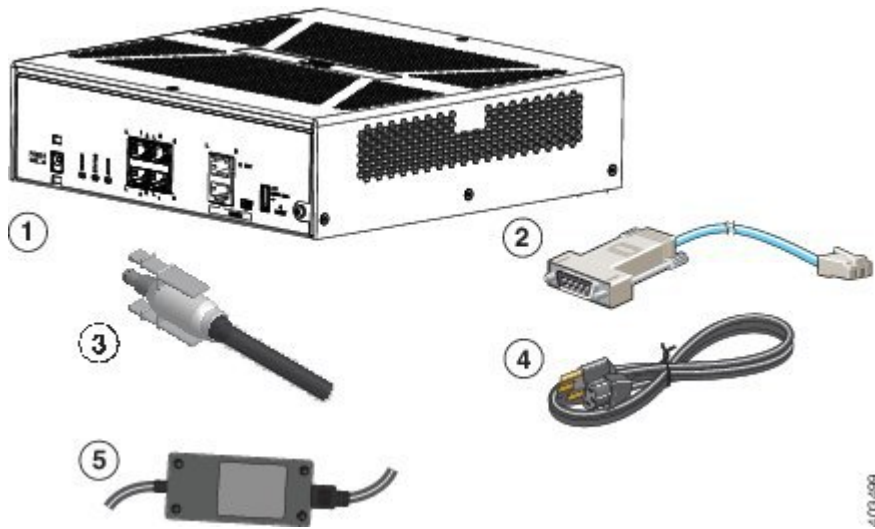

1	Chassis	2	Blue Console Cable PC Terminal Adapter
---	---------	---	--

3	Power cord retention lock	4	Power cord
5	Power supply		

Front Panel

The following figure shows the front panel of the ASA 5506-X. The ASA 5506W-X has an identical front panel. Note that there are no connectors or LEDs on the front panel.

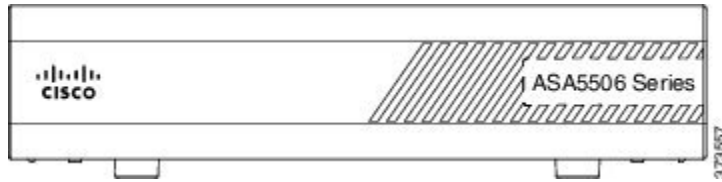

The following figure shows the front panel of the ASA 5506H-X. Note that there are no connectors or LEDs on the front panel.

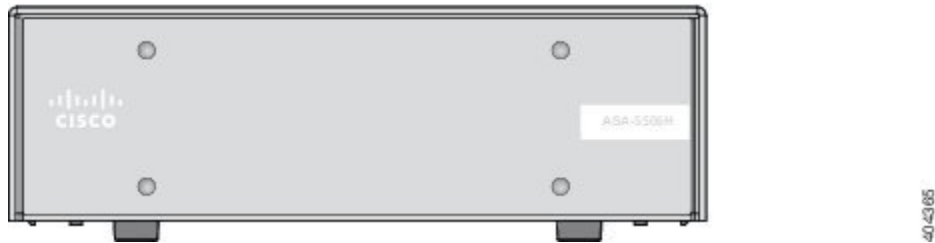

Rear Panel

The following figure shows the rear panel of the ASA 5506-X. The 5506W-X has an identical rear panel.

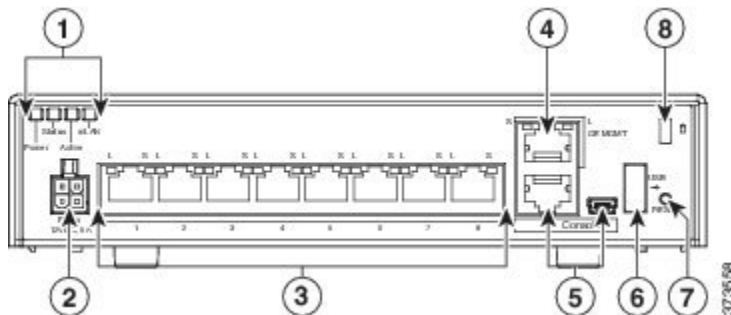

1	Status LEDs	The locations and meanings of the status LEDs are described in Status Lights , on page 8.
---	-------------	---

2	Power cord socket	The chassis power-supply socket. See Power Supply Modules, on page 12 for more information about the chassis power supply. Note The ASA is powered on when you plug in the AC power supply.
3	Network data ports	Eight Gigabit Ethernet RJ-45 (8P8C) network I/O interfaces. The ports are numbered (from left to right) 1, 2, 3, 4, 5, 6, 7, 8. Each port includes a pair of LEDs, one each for connection status and link status. The ports are named and numbered Gigabit Ethernet 1/1 through Gigabit Ethernet 1/8. See Network Ports, on page 10 for additional information.
4	Management port	A Gigabit Ethernet interface restricted to network management access only. Connect with an RJ-45 cable.
5	Console ports	Two serial ports, a mini USB Type B, and a standard RJ-45 (8P8C), are provided for management access via an external system. See Console Ports, on page 10 for additional information.
6	USB port	A standard USB Type A port is provided that allows the attachment of an external device, such as mass storage. See Internal and External Flash Storage, on page 11 for additional information.
7	Reset button	A small recessed button that if pressed for longer than three seconds resets the ASA to its default “as-shipped” state following the next reboot. Configuration variables are reset to factory default. However, the flash is not erased and no files are removed. Note You can use the service sw-reset-button to disable the reset button. The default is enabled. Note Pressing the reset button on the ASA 5506W-X does not affect the AP configuration, but it causes any unsaved AP configuration to be lost, because the system has rebooted. After the system reboots, if you want a default AP configuration, use the hw-module module wlan recover configuration command to recover the AP configuration.
8	Lock slot	The slot accepts a standard Kensington T-bar locking mechanism for securing the ASA.

The following figure shows the rear panel of the 5506H-X.

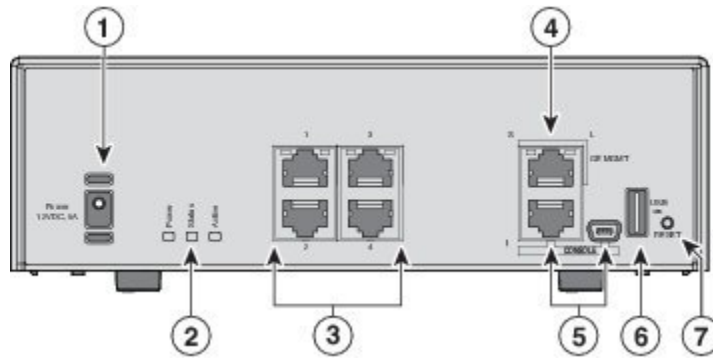

401-384

1	Power cord socket.	The chassis power-supply socket. See Power Supply Modules, on page 12 for more information about the chassis power supply. Note The ASA is powered on when you plug in the AC power supply.
2	Status LEDs	The locations and meanings of the status LEDs are described in Status Lights, on page 8 .
3	Network data ports	Four Gigabit Ethernet RJ-45 (8P8C) network I/O interfaces. The ports are numbered (from top to bottom) 1, 2, 3, 4. Each port includes a pair of LEDs, one each for connection status and link status. The ports are named and numbered Gigabit Ethernet 1/1 through Gigabit Ethernet 1/4. See Network Ports, on page 10 for additional information.
4	Management port	A Gigabit Ethernet interface restricted to network management access only. Connect with an RJ-45 cable.
5	Console ports	Two serial ports, a standard RJ-45 (8P8C), and a mini USB Type B, are provided for management access via an external system. See Console Ports, on page 10 for additional information.
6	USB port	A standard USB Type A port is provided that allows the attachment of an external device, such as mass storage. See Internal and External Flash Storage, on page 11 for additional information.
7	Reset button	A small recessed button that if pressed for longer than three seconds resets the ASA to its default “as-shipped” state following the next reboot. Configuration variables are reset to factory default. However, the flash is not erased and no files are removed. Note You can use the service sw-reset-button to disable the reset button. The default is enabled.

Status Lights

Facing the rear of the ASA 5506-X and ASA 5506W-X chassis, the status lights are located on the top left edge (facing the front of the chassis, they are in the back right corner of the top). The following figure shows the lights on the top left edge.

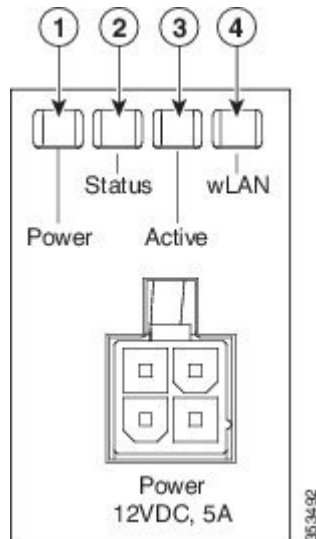

Facing the rear of the ASA 5506H-X the status lights, are located on the bottom left of the chassis. The network port lights are at the top sides of each network port. See [Rear Panel](#), on page 5 for more information.

	LED	Description
1	Power	<p>Power supply status:</p> <ul style="list-style-type: none"> • Unlit – Power supply off. • Solid green – Power supply on. <p>See Power Supply Modules, on page 12 for additional power information specific to your specific ASA.</p>
2	Status	<p>System operating status:</p> <ul style="list-style-type: none"> • Green – Normal system function. • Amber – Critical alarm indicating one or more of the following: <ul style="list-style-type: none"> • Major failure of a hardware or software component. • Over-temperature condition. • Power voltage outside the tolerance range.

	LED	Description
3	Active	<p>Status of the failover pair:</p> <ul style="list-style-type: none"> • Solid green – Failover pair operating normally. The LED is green always unless the ASA is in an HA pair. • Amber – When the ASA is in an HA pair, the LED is amber for the Standby unit. • Unlit – Failover is not operational.
4	wLAN	<p>Not in use on the ASA 5506-X or the ASA 5506-H.</p> <p>Association status of the wireless connection on the ASA 5506W-X:</p> <ul style="list-style-type: none"> • Chirping green – Normal operating condition, but no wireless client is present. • Green – Normal operating condition, at least one wireless client is associated. • Blinking amber – Software upgrade in progress. • Green, red, amber sequence – Discovery/join process in progress. • Blinking red – Ethernet link not operational. • Unlit – Wireless is not operational.
	Network port status	<p>On the rear panel of the ASA 5506-X and ASA 5506W-X, a pair of LEDs (link status and connection status) for each of the eight Gigabit Ethernet network ports, and the Gigabit Ethernet management port.</p> <p>On the rear panel of the ASA 5506H-X, a pair of LEDs (link status and connection status) for each of the four Gigabit Ethernet network ports, and the Gigabit Ethernet Management port.</p> <p>Link status (L):</p> <ul style="list-style-type: none"> • Unlit – No link, or port is not in use. • Solid green – Link established. • Flashing green – Link activity. <p>Connection-speed status (S):</p> <ul style="list-style-type: none"> • One blink every three seconds – 10 Mbps. • Two rapid blinks – 100 Mbps. • Three rapid blinks – 1000 Mbps.

Network Ports

There are eight 10/100/1000 baseT Ethernet network ports on the ASA 5506-X and ASA 5506W-X. Each RJ-45 (8P8C) copper port supports auto MDI/X as well as auto-negotiation for interface speed, duplex, and other negotiated parameters, and are MDI/MDIX compliant.

In addition, the ASA 5506W-X has a Gigabit Ethernet 1/9 port that is internal and connects to the WLAN module.

The ASA 5506H-X has four 10/100/1000 baseT Ethernet network ports. Each RJ-45 (8P8C) copper port supports auto MDI/X as well as auto-negotiation for interface speed, duplex, and other negotiated parameters, and are MDI/MDIX compliant.

Port Numbering

Looking at the rear of the ASA 5506-X and ASA 5506W-X, where the ports are located, port 1 is on the left, and port 8 is on the right, next to the console and management ports. Each port is accompanied by a pair of LEDs, one each for link status (L) and connection status (S). The ports are named and numbered Gigabit Ethernet 1/1 through Gigabit Ethernet 1/8. The ports are named and numbered Gigabit Ethernet 1/1 through Gigabit Ethernet 1/4.

The four ports on the ASA 5506H-X are numbered differently. Looking at the rear of the ASA 5506H-X where the ports are located, ports 1 and 3 are at the top from left to right. Ports 2 and 4 are on the bottom from left to right. The ports are between the Status LEDs and the console and management ports. The ports are named and numbered Gigabit Ethernet 1/1 through Gigabit Ethernet 1/4.

Console Ports

The ASA has two external console ports, a standard RJ-45 port and a Mini USB Type B serial port. Only one console port can be active at a time. When a cable is plugged into the USB console port, the RJ-45 port becomes inactive. Conversely, when the USB cable is removed from the USB port, the RJ-45 port becomes active. The console ports do not have any hardware flow control. You can use the command-line interface (CLI) to configure your ASA through either serial console port by using a terminal server or a terminal emulation program on a computer.

In addition, the AP module inside the ASA 5506W-X has a console port, which is accessible by sessioning to the module's console via the **session wlan console** command in the ASA CLI.

See [Connect to a Console Terminal or PC](#), on page 39 for the procedure to install a console terminal.

RJ-45 Port

The RJ-45 (8P8C) port supports RS-232 signaling to an internal UART controller. The RJ-45 console port does not support a remote dial-in modem. You can use a standard management cable (Cisco part number 72-3383-01) to convert the RJ45-to-DB9 connection if necessary.

Mini USB Type B Port

The Mini USB Type B port lets you connect to a USB port on an external computer. For Linux and Macintosh systems, no special driver is required. For Windows systems, you must download and install a USB driver (available on software.cisco.com). You can plug and unplug the USB cable from the console port without affecting Windows HyperTerminal operations. We recommend shielded USB cables with properly terminated shields. Baud rates for the USB console port are 1200, 2400, 4800, 9600, 19200, 38400, 57600, and 115200 bps.

**Note**

For Windows operating systems, you must install a Cisco Windows USB Console Driver on any PC connected to the console port before using the USB console port. See [Connect to the Console Port with Microsoft Windows, on page 39](#) for information on installing the driver.

Internal and External Flash Storage

The ASA contains one internal USB flash drive, and a standard USB Type A port that you can use to attach an external device. The USB port can provide output power of 5 volts, up to a maximum of 500 mA (5 USB power units).

Internal USB Device

An embedded eUSB device is used as the internal flash; it is identified as *disk0*.

External USB Drive (Optional)

You can use the external Type A USB port to attach a data-storage device. The external USB drive identifier is *disk1*. When the ASA is powered on, a connected USB drive is mounted as *disk1* and is available for you to use. Additionally, the file-system commands that are available to *disk0* are also available to *disk1*, including **copy**, **format**, **delete**, **mkdir**, **pwd**, **cd**, and so on.

If you insert a USB drive with more than one partition, only the first partition is mounted.

FAT-32 File System

The ASA only supports FAT-32-formatted file systems for the internal eUSB and external USB drives. If you insert an external USB drive that is not in FAT-32 format, the system mounting process fails, and you receive an error message. You can enter the command **format disk1**: to format the partition to FAT-32 and mount the partition to *disk1* again; however, data might be lost.

Solid State Drive

The ASA 5506-X and ASA 5506W-X ship with an SSD installed that provides storage support. The SSD has 50 GB of useable space and is not field-replaceable. You must return the entire ASA to Cisco for drive replacement. The SSD is used by the software; there is no user access to the SSD.

The ASA 5506H-X ships with a ruggedized SSD installed that provides storage support. The SSD is an industrial-rated part so that it operates over the extended temperature range that the ASA 5506H-X supports.

The SSD has 50 GB of useable space and is not field-replaceable. You must return the entire ASA to Cisco for drive replacement. The SSD is used by the software; there is no user access to the SSD.

Power Supply Modules

The ASA 5506-X and ASA 5506W-X ship with a 12V brick power supply that provides 60 W. See [Power Supply Considerations, on page 27](#) for additional site-related power information.

The ASA 5506H-X ships with a ruggedized 5V-5.3V barrel power supply that provides 22 W. The power supply supports an extended temperature range of -25°C to 60°C. See [Power Supply Considerations, on page 27](#) for additional site-related power information.

Hardware Specifications

The following table contains hardware specifications for the ASA.

Mounting	<ul style="list-style-type: none"> • Desk mountable; see Desktop Mount the ASA, on page 29 for more information. <p>Caution Do not stack the ASA chassis on top of another ASA chassis. If you stack the units, they will overheat, which causes the units to power cycle.</p> <ul style="list-style-type: none"> • Rack mountable in a rack tray. You can place two chassis side by side. See Rack Mount the ASA, on page 32 for more information. <p>Note One ASA 5506H-X fits in the rack tray. See Rack Mount the ASA, on page 32 for more information.</p> <ul style="list-style-type: none"> • Wall mountable (ASA 5506-X and ASA 5506W-X only); see Wall Mount the ASA, on page 30 for more information. • DIN rail mountable (ASA 5506H-X only); the DIN rail is available for order from Cisco Systems. See the DIN rail mount instructions.
Dimensions	<p>7.87 x 9.23 x 1.94 in (19.99 x 23.44 x 4.93 cm) including the feet (ASA 5506-X and ASA 5506W-X).</p> <p>9.1 x 9.1 x 2.8 in (23.11 x 23.11 x 7.11 cm) including the feet (ASA 5506H-X).</p>
Weight	<p>4 lb (ASA 5506-X and ASA 5506W-X)</p> <p>6.7 lb (ASA 5506H-X)</p>
DRAM	<p>Total: 4 GB</p> <p>Allotted to FW/VPN: 1.8 GB</p> <p>Allotted to Module: 2.2 GB</p>
Internal flash	8 GB

Power	60 W (ASA 5506-X and ASA 5506W-X) 22 W (5506H-X)
Temperature	Operating: 32°F to 104°F (0°C to 40°C) (ASA 5506-X and ASA 5506W-X) ¹ -4°F to 140°F (-20°C to 60°C) (ASA 5506H-X) ² Nonoperating: -13°F to 158°F (-25°C to 70°C) (ASA 5506-X and ASA 5506W-X) -40°F to +185°F (-40° C to +85° C) (ASA 5506H-X)
Relative humidity	Operating: 90% (ASA 5506-X and ASA 5506W-X) Operating: 95% (ASA 5506H-X) Nonoperating: 10% to 90%
Maximum altitude	Operating: 10,000 ft (3048 m) Nonoperating: 15,000 ft (4572 m)
IP rating	IP40 per IEC60529 (ASA 5506H-X)
Extended vibe and shock	IEEE1613, IEC60068-2, IEC 61850-3 (ASA 5506H-X)

¹ Derate the maximum operating temperature 1.5 degrees C per 1000 ft above sea level.

² Derate the maximum operating temperature 1.5 degrees C per 1000 ft above 6,000 feet elevation.

Power Cord Specifications



Note

This section applies only to the ASA 5506-X and ASA 5506W-X. It does NOT apply to the ASA 5506H-X.

Each power supply has a separate power cord. Standard power cords are available for connection to the security appliance.

If you do not order the optional power cord with the system, you are responsible for selecting the appropriate power cord for the product. Using a non-compatible power cord with this product may result in electrical safety hazard. Orders delivered to Argentina, Brazil, and Japan must have the appropriate power cord ordered with the system.

Only the approved power cords provided with the security appliance are supported. The following table lists the supported power cords.

Table 1: Supported Power Cords

Description	Amperage	Voltage	Plug	Connector
-------------	----------	---------	------	-----------

CAB-ACE AC Power Cord (Europe) C13, CEE 7	10A	250V	CEE 7 VII	IEC 60320/C13
CAB-AC AC power cord (North America) C13, NEMA 5-15P	10A	125V	NEMA 5-15P	IEC 60320/C13
CAB-ACA AC power cord (Australia) C13, AS 3112	10A	250V	A.S. 3112	IEC 60320/C13
CAB-ACI AC power cord (Italy) C13, CEI 23-16	10A	250V	CEI23-16-VII	IEC 60320/C13
CAB-ACR AC power cord (Argentina) C13, CEI 23-16	10A	250V	IRAM 2073	IEC 60320/C13
CAB-ACS AC power cord (Switzerland)	10A	250V	SEV 1011	IEC 60320/C13
CAB-ACU AC power cord (United Kingdom)	10A	250V	BS1363a/SS145	IEC 60320/C13
CAB-JPN-3PIN Power cord 3PIN (Japan)	12A	125V	JIS C8303	IEC 60320/C13
AIR-PWR-CORD-SA AIR line cord (South America)	10A	250V	SABS 1661	IEC 60320/C13
CAB-ACC Power cord (China)	10A	250V	GB2009.1-2008	IEC 60320/C13

CAB-IND-10A Power cord (India)	10A	250V	IS 6538-1971	IEC 60320/C13
CAB-C13-ACB AC power cord (Brazil) C13, NBR 1436	10A	250V	NBR 14136	IEC 60320/C13
CAB-AC-C13-KOR AC power cord (Korea) C13	10A	250V	KSC8305	IEC 60320/C13
CAB-ACTW AC power cord (Taiwan) C13	10A	250V	CNS10917	IEC 60320/C13

The following illustrations show the cord, connector, and plug for each country listed above.

Figure 3: CAB-ACE (Europe)

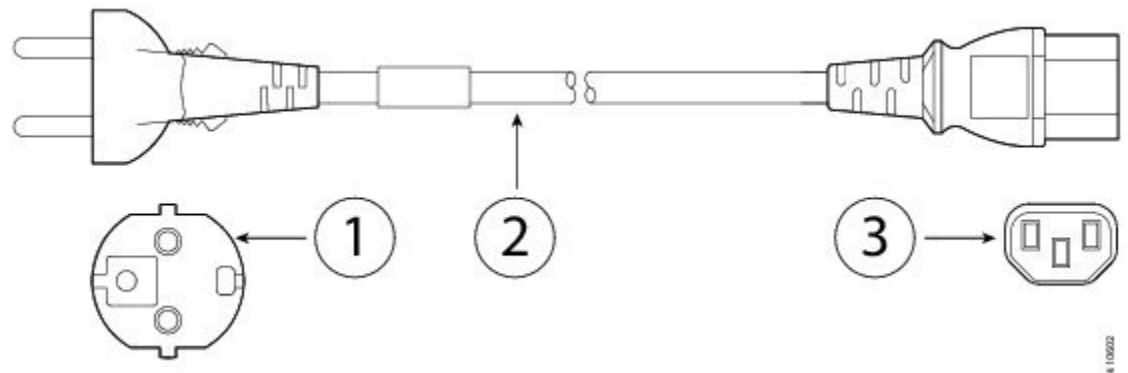

1	Plug: CEE 7 VII	2	Cordset rating: 10A, 250V
3	Connector: IEC 60320/C13		

Figure 4: CAB-AC (North America)

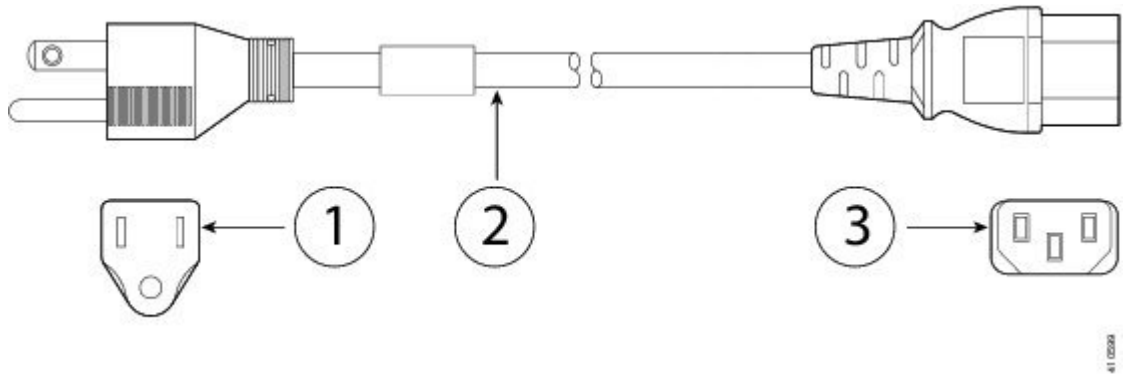

1	Plug: NEMA 5-15P	2	Cord set rating: 10A, 125V
3	Connector: IEC 60320/C13		

Figure 5: CAB-ACA (Australia)

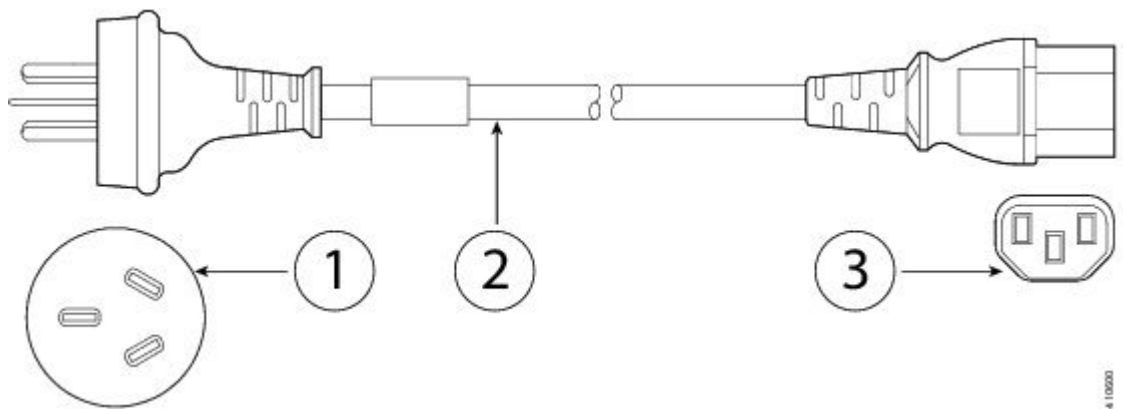

1	Plug: A.S. 3112	2	Cord set rating: 10A, 250V
3	Connector: IEC 60320/C13		

Figure 6: CAB-ACI (Italy)

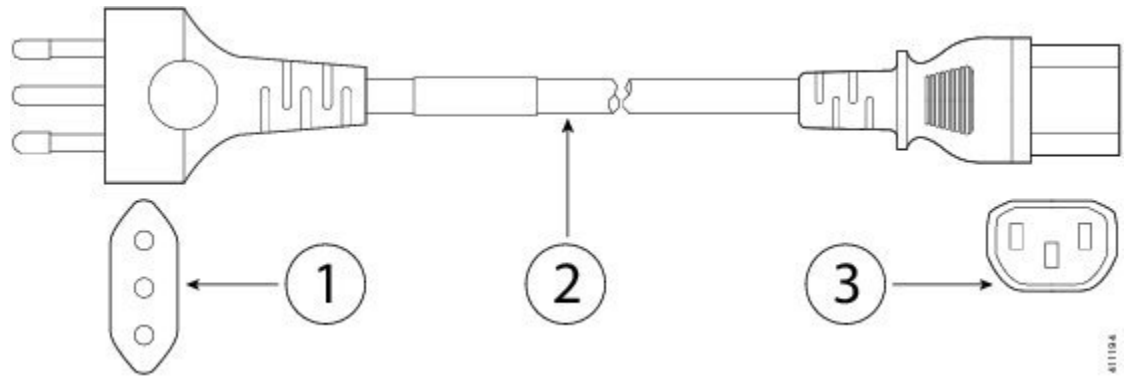

1	Plug: CE123-16-VII	2	Cord set rating: 10A, 250V
3	Connector: IEC 60320/C13		

Figure 7: CAB-ACR (Argentina)

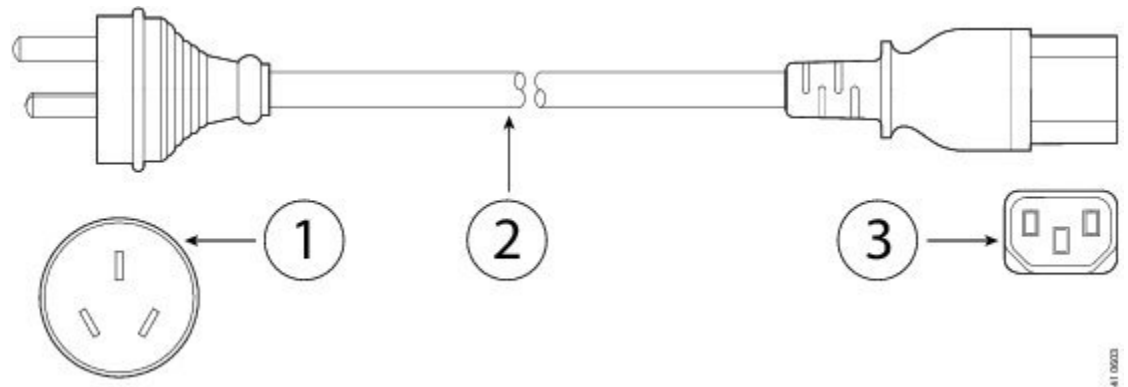

1	Plug: IRAM 2073	2	Cord set rating: 10A, 250V
3	Connector: IEC 60320/C13		

Figure 8: CAB-ACS (Switzerland)

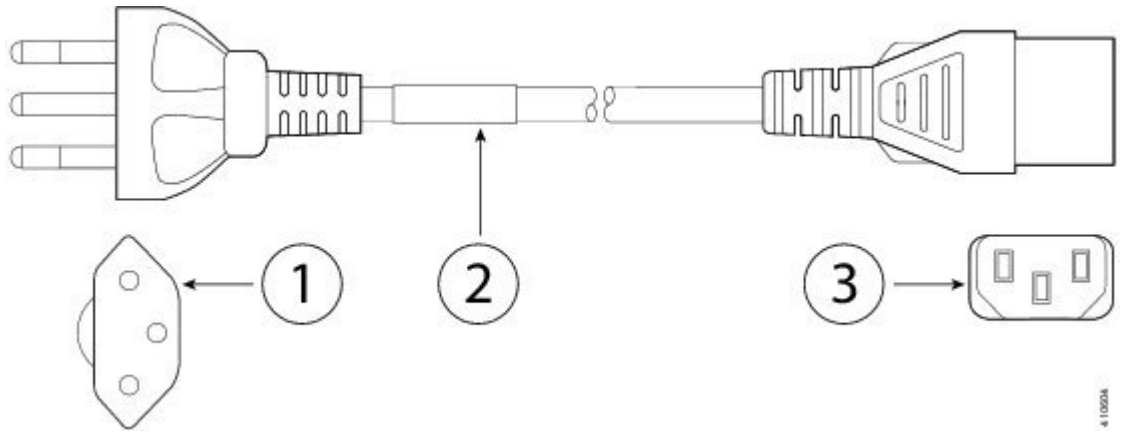

1	Plug: SEV 1011	2	Cord set rating: 10A, 250V
3	Connector: IEC 60320/C13		

Figure 9: CAB-ACU (United Kingdom)

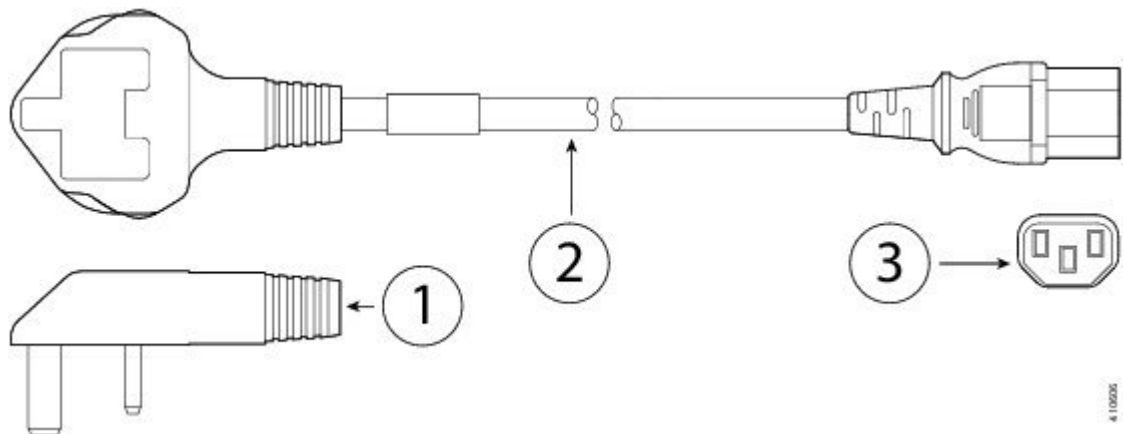

1	Plug: BS1363a/SS145	2	Cord set rating: 10A, 250V
3	Connector: IEC 60320/C13		

Figure 10: CAB-JPN-3PIN (Japan)

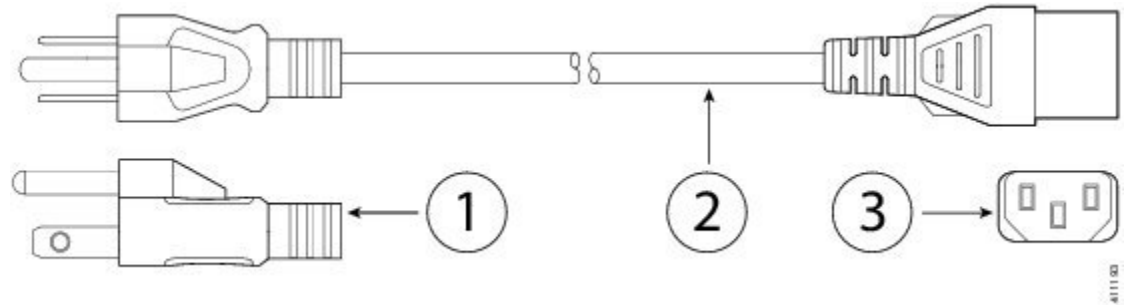

1	Plug: JIS C8303	2	Cord set rating: 12A, 125V
3	Connector: IEC 60320/C13		

Figure 11: AIR-PWR-CORD-SA (South Africa)

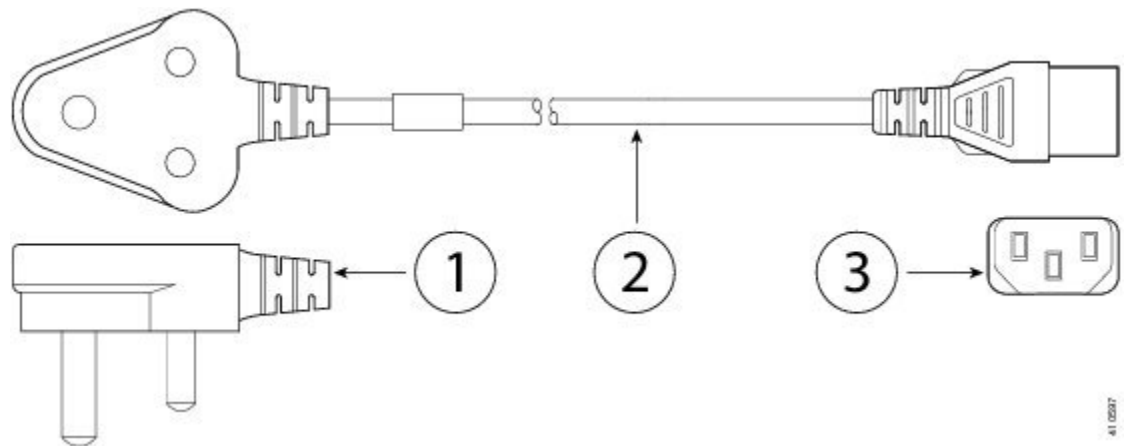

1	Plug: SABS 1661	2	Cord set rating: 10A, 250V
3	Connector: IEC 60320/C13		

Figure 12: CAB-ACC (China)

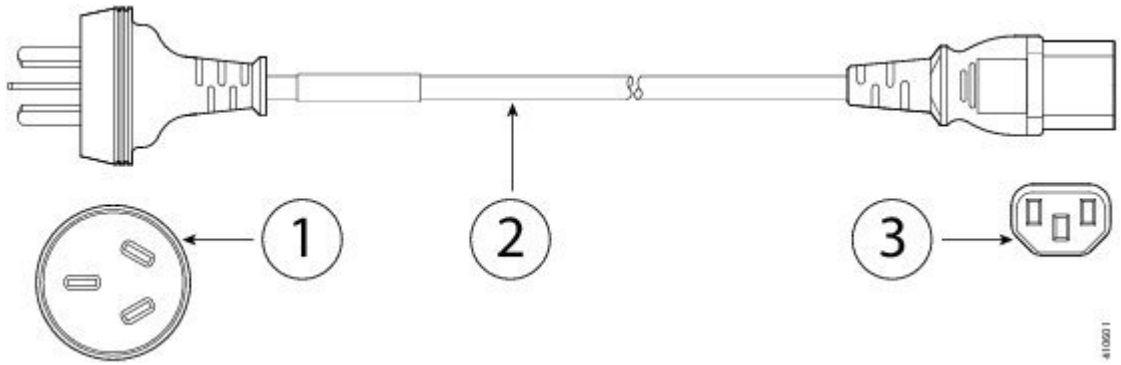

1	Plug: GB2009.1-2008	2	Cord set rating: 10A, 250V
3	Connector: IEC 60320/C13		

Figure 13: CAB-IND-10A (India)

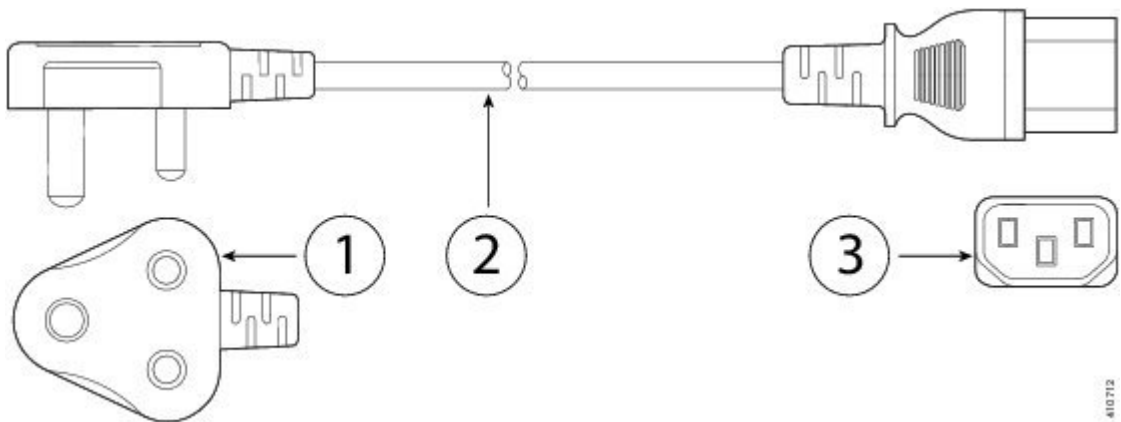

1	Plug: IS 6538-1971	2	Cord set rating: 10A, 250V
3	Connector: IEC 60320/C13		

Figure 14: CAB-C13-ACB (Brazil)

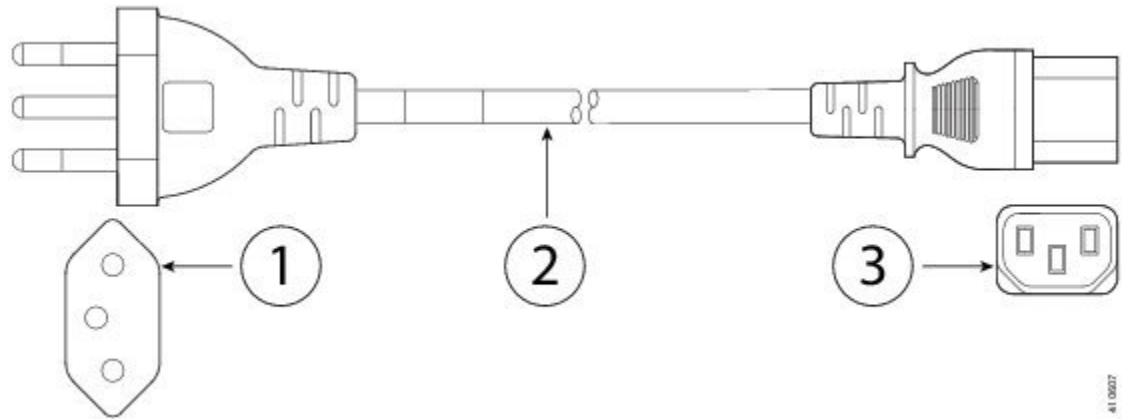

1	Plug: NBR 14136	2	Cord set rating: 10A, 250V
3	Connector: IEC 60320/C13		

Figure 15: CAB-AC-C13-KOR (Korea)

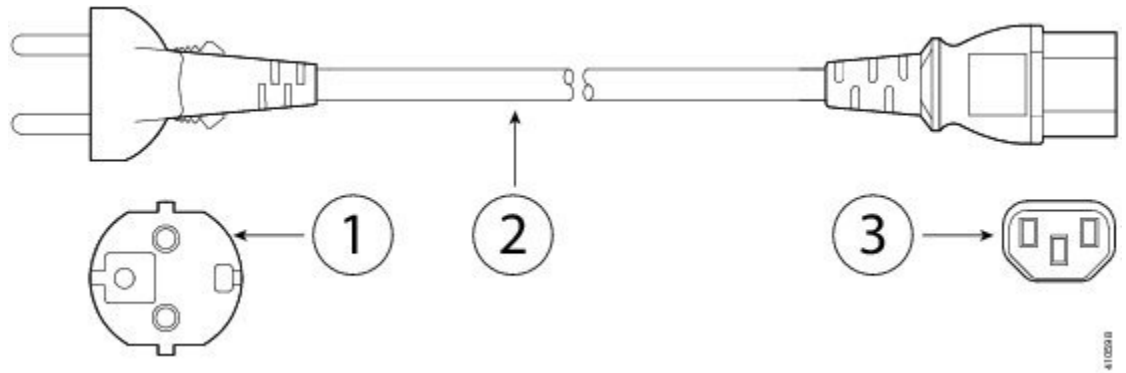

1	Plug: KSC8305	2	Cord set rating: 10A, 250V
3	Connector: IEC 60320/C13		

Figure 16: CAB-ACTW (Taiwan)

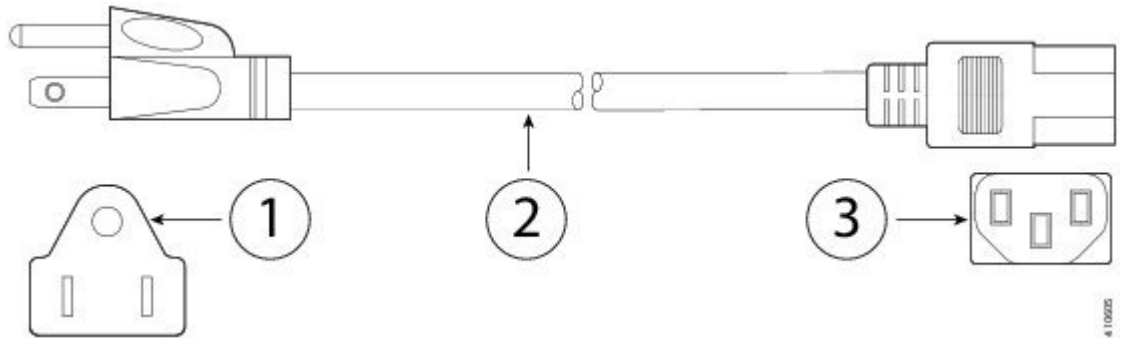

1	Plug: CNS10917	2	Cord set rating: 10A, 250V
3	Connector: IEC 60320/C13		



CHAPTER 2

Prepare for Installation

This chapter prepares you to install your ASA, and contains the following topics:

- [Installation Warnings, page 23](#)
- [Position the ASA, page 24](#)
- [Mount and Deployment Preparation for the ASA 5506W-X, page 25](#)
- [Safety Recommendations, page 25](#)
- [Site Environment , page 26](#)

Installation Warnings

Be sure to read the [Regulatory Compliance and Safety Information](#) document before installing the ASA.

Take note of the following warnings:



Warning

Read the installation instructions before connecting the system to the power source.



Warning

Before working on a chassis or working near power supplies, unplug the power cord on AC units; disconnect the power at the circuit breaker on DC units.



Warning

Before working on equipment that is connected to power lines, remove jewelry (including rings, necklaces, and watches). Metal objects will heat up when connected to power and ground and can cause serious burns or weld the metal object to the terminals.



Warning

During this procedure, wear grounding wrist straps to avoid ESD damage to the card. Do not directly touch the backplane with your hand or any metal tool, or you could shock yourself.

**Warning**

This product requires short-circuit (overcurrent) protection to be provided as part of the building installation. Install only in accordance with national and local wiring regulations.

**Warning**

To avoid electric shock, do not connect safety extra-low voltage (SELV) circuits to telephone-network voltage (TNV) circuits. LAN ports contain SELV circuits, and WAN ports contain TNV circuits. Some LAN and WAN ports both use RJ-45 connectors. Use caution when connecting cables.

**Warning**

This equipment must be grounded. Never defeat the ground conductor or operate the equipment in the absence of a suitably installed ground conductor. Contact the appropriate electrical inspection authority or an electrician if you are uncertain that suitable grounding is available.

**Warning**

Ultimate disposal of this product should be handled according to all national laws and regulations.

**Warning**

Installation of the equipment must comply with local and national electrical codes.

**Warning**

The device is designed to work with TN power systems.

Position the ASA

Whether positioning the ASA on a desktop, on a non-rack closet shelf, or mounting it on a wall, consider the following:

**Caution**

Do not stack the ASA chassis on top of another ASA chassis. If you stack the units, they will overheat, which causes the units to power cycle.

- Be sure to choose an area where the ASA is out of the way to make sure it is not bumped or accidentally dislodged. The appliance has “feet” on the bottom so it does not sit flush where placed, thus allowing proper air circulation through and around it. Make sure that the appliance is not tightly enclosed or crowded by other objects that might impede proper circulation.
- Choose a location that lets you easily bring the power cord and Ethernet and console cables to the ASA, with plenty of slack and yet tucked away, so they cannot be inadvertently unplugged.

Mount and Deployment Preparation for the ASA 5506W-X

Before you mount and deploy the ASA 5506W-X, we recommend that you perform a site survey (or use the site planning tool) to determine the best location to install your wireless ASA.

Make sure you have the following information about your wireless network available:

- ASA 5506W-X locations
- ASA 5506W-X mounting options (see [Position the ASA](#), on page 24 for mounting options)
- ASA 5506W-X power options

**Note**

We recommend that you make a site map showing the ASA 5506W-X locations so you can record the device MAC addresses from each location and provide them to the person who is planning or manage your wireless network.

Safety Recommendations

Use the information in the following sections to help ensure your safety and to protect the chassis. This information may not address all potentially hazardous situations in your working environment, so be alert and exercise good judgment at all times.

Observe these safety guidelines:

- Keep the area clear and dust-free before, during, and after installation.
- Keep tools away from walkways, where you and others might trip over them.
- Do not wear loose clothing or jewelry, such as earrings, bracelets, or chains that could get caught in the chassis.
- Wear safety glasses if you are working under any conditions that might be hazardous to your eyes.
- Do not perform any action that creates a potential hazard to people or makes the equipment unsafe.
- Never attempt to lift an object that is too heavy for one person.

Maintain Safety with Electricity

Before working on a chassis, be sure the power cord is unplugged.

Follow these guidelines when working on equipment powered by electricity:

- Before beginning procedures that require access to the interior of the chassis, locate the emergency power-off switch for the room in which you are working. Then, if an electrical accident occurs, you can act quickly to turn off the power.
- Do not work alone if potentially hazardous conditions exist anywhere in your work space.
- Never assume that power is disconnected; always check.
- Look carefully for possible hazards in your work area, such as moist floors, ungrounded power extension cables, frayed power cords, and missing safety grounds.
- If an electrical accident occurs:
 - Use caution; do not become a victim yourself.
 - Disconnect power from the system.
 - If possible, send another person to get medical aid. Otherwise, assess the condition of the victim, and then call for help.
 - Determine whether the person needs rescue breathing or external cardiac compressions; then take appropriate action.
- Use the chassis within its marked electrical ratings and product usage instructions.

Prevent Electrostatic Discharge Damage

Electrostatic discharge (ESD) occurs when electronic components are improperly handled, and it can damage equipment and impair electrical circuitry, resulting in intermittent or complete failure.

Always follow ESD-prevention procedures when removing and replacing components. Ensure that the chassis is electrically connected to an earth ground. Wear an ESD-preventive wrist strap, ensuring that it makes good skin contact. Connect the grounding clip to an unpainted surface of the chassis frame to safely ground ESD voltages. To properly guard against ESD damage and shocks, the wrist strap and cord must operate effectively. If no wrist strap is available, ground yourself by touching the metal part of the chassis.

For safety, periodically check the resistance value of the anti-static strap, which should be between one and 10 megohms.

Site Environment

You can place the chassis on a desktop, mount it on a wall, or on a rack shelf. The location of the chassis and the layout of the equipment rack or wiring room are extremely important for proper system operation. Placing equipment too close together with inadequate ventilation and inaccessible panels can cause system malfunctions and shutdowns. Improper placement can also make it difficult for you to access the chassis for maintenance.



Warning

Under no circumstances should you stack more than one chassis on top of one another. This disrupts cooling air flow to the ASAs and causes damage to the hardware.

See [Hardware Specifications](#), on page 12 for information about physical specifications.

When planning the site layout and equipment locations, consider the information in the next section to help avoid equipment failures and reduce the possibility of environmentally caused shutdowns. If you are currently experiencing shutdowns or unusually high error rates with your existing equipment, these considerations may help you isolate the cause of failures and prevent future problems.

Site Considerations

Considering the following helps you plan an acceptable operating environment for the chassis, and avoid environmentally caused equipment failures.

- Electrical equipment generates heat. Ambient air temperature might not be adequate to cool equipment to acceptable operating temperatures without adequate circulation. Ensure that the room in which you operate your system has adequate air circulation.
- Ensure that the chassis cover is secure. The chassis is designed to allow cooling air to flow effectively within it. An open chassis allows air leaks, which may interrupt and redirect the flow of cooling air from the internal components.
- Always follow the ESD-prevention procedures described previously to avoid damage to equipment. Damage from static discharge can cause immediate or intermittent equipment failure.

Power Supply Considerations

When installing the chassis, consider the following:

- Check the power at the site before installing the chassis to ensure that it is “clean” (free of spikes and noise). Install a power conditioner, if necessary, to ensure proper voltages and power levels in the appliance-input voltage.
- Install proper grounding for the site to avoid damage from lightning and power surges.
- The chassis does not have a user-selectable operating range. Refer to the label on the chassis for the correct appliance input-power requirement.
- Install an uninterruptible power source for your site, if possible.

Equipment Rack Configuration Considerations

Consider the following when planning an equipment-rack configuration:

- If you are mounting a chassis in an open rack, make sure that the rack frame does not block the intake or exhaust ports.
- Be sure enclosed racks have adequate ventilation. Make sure that the rack is not overly congested as each chassis generates heat. An enclosed rack should have louvered sides and a fan to provide cooling air.
- In an enclosed rack with a ventilation fan in the top, heat generated by equipment near the bottom of the rack can be drawn upward and into the intake ports of the equipment above it in the rack. Ensure that you provide adequate ventilation for equipment at the bottom of the rack.

- Baffles can help to isolate exhaust air from intake air, which also helps to draw cooling air through the chassis. The best placement of the baffles depends on the airflow patterns in the rack. Experiment with different arrangements to position the baffles effectively.



Mount and Connect the ASA

This section describes how to mount the ASA, and contains the following topics:



Note

Do not remove the rubber feet included with the ASA because they are needed for proper cooling for all mounting orientations.

- [Desktop Mount the ASA, page 29](#)
- [Wall Mount the ASA, page 30](#)
- [Rack Mount the ASA, page 32](#)
- [Install the ASA 5506H-X in a DIN Rail, page 34](#)
- [Connect Cables, Turn on Power, and Verify Connectivity, page 37](#)
- [Connect to a Console Terminal or PC, page 39](#)

Desktop Mount the ASA

You can mount the ASA on a desktop by placing it on a desk in a horizontal position. Make sure there are no blockages or obstructions within one inch of the top of the ASA or within .5 inch of the sides and back, so that nothing interferes with cooling. Do not remove the rubber feet included with the ASA. They are also needed for proper cooling.

**Caution**

Do not stack the ASA chassis on top of another ASA chassis. If you stack the units, they will overheat, which causes the units to power cycle.

Wall Mount the ASA

Follow these steps to mount your ASA on a wall. You can purchase a wall mount kit. The part number for the wall mount kit is ASA5506-WALL-MNT=.

-
- Step 1** Choose a location on the desired wall for the ASA.
- Step 2** Use the two Cisco-provided screws and anchors from the optional wall-mount kit. If you are mounting the ASA onto something other than drywall, such as wood or sheet metal, anchors may not be required.
- Step 3** Use a pencil, ruler, and level to mark locations for the two mounting screws. The width and length of the ASA are 7.87 x 9.23 inches (20 x 23.44 cm). The mounting holes in the chassis are in the middle length-wise (that is, 6.372 inches from front and back), while the holes are inset from the opposite edges 0.75 inches (1.9 cm).
Thus, you need to make two level marks 6.37, or approximately 6-3/8, inches (16.18 cm) apart.

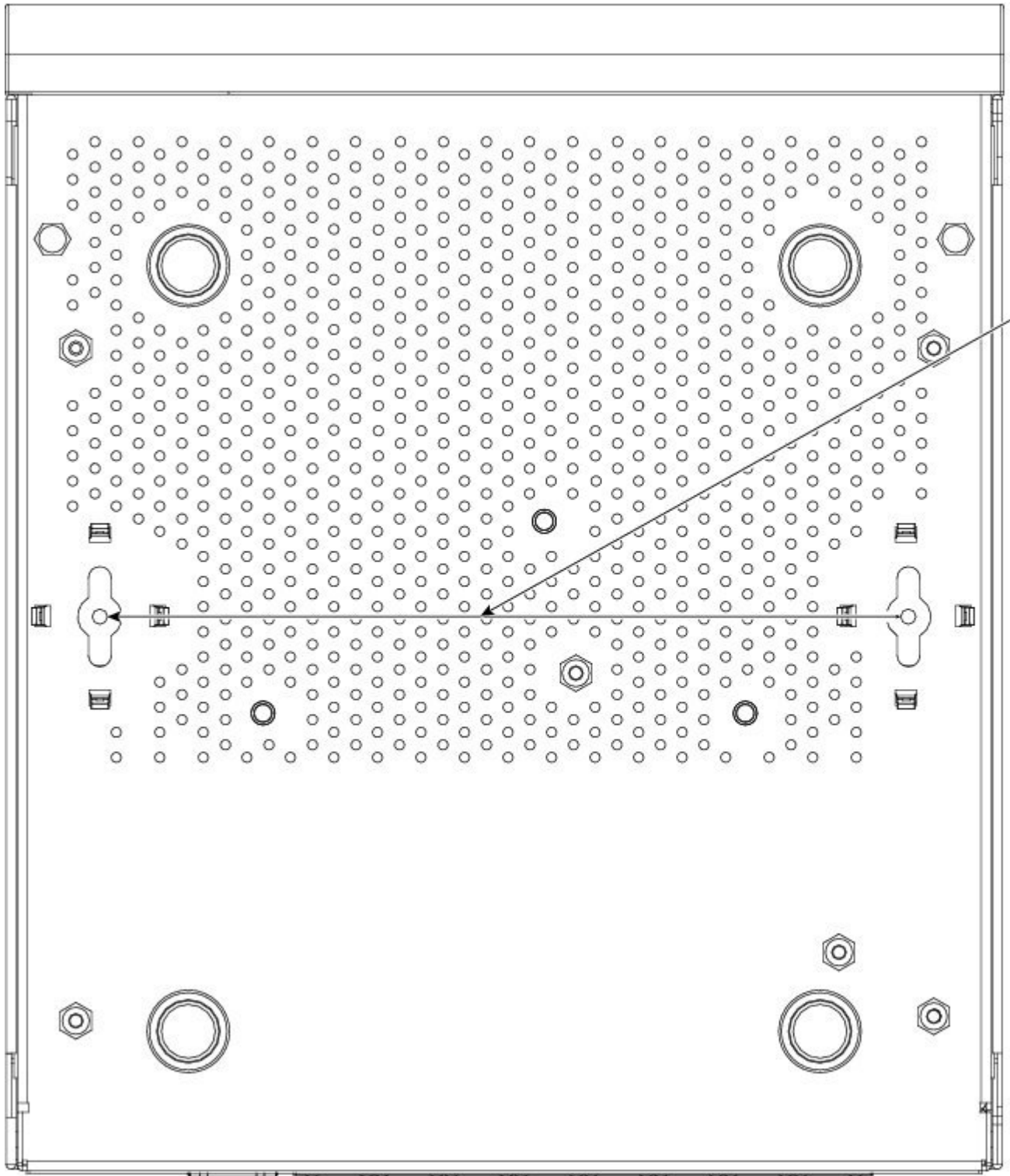

Step 4 Drill a hole into the wall at each mark.

These holes should be slightly smaller in diameter than your anchors. The recommended drill hole size is 3/16".

- Step 5** Insert the anchors into the holes and be sure they are properly seated.
- Step 6** Fasten each screw into its anchor until it protrudes about 1/4 inch.
- Step 7** Pick up the ASA, align the screws in the anchors with the holes in the bottom of the chassis, move the ASA toward the wall until the screw heads are in the chassis, and then slide the ASA down until it rests on the screws. You can only mount the chassis with the front panel oriented toward either the ceiling or the floor. Wall mounting in other orientation is not supported.
-

What to Do Next

You can now install the cables and power cord, as described in [Connect Cables, Turn on Power, and Verify Connectivity](#), on page 37.

Rack Mount the ASA

Follow these steps to mount the ASA to a rack-mount shelf.



Note You mount only one ASA 5506H-X in the rack-mount shelf.

- Step 1** Place the ASA upside down on a large, stable work area. If you are installing two ASAs in the shelf, place the second ASA beside the first, also upside down.
- Step 2** Invert the sliding trays and position the ASA(s) on top of them such that the front of the device(s) and the front of the tray are in the same direction.
- Step 3** Adjust the position of the first ASA and the tray until the three mounting holes in the dimples in the bottom of the shelf are aligned with the mounting holes in the bottom of the ASA.
- Step 4** Tighten the captive tray screws into the shelf to lock it into place.

Figure 17: ASA 5506-X and ASA 5506W-X in the Rack-Mount Shelf

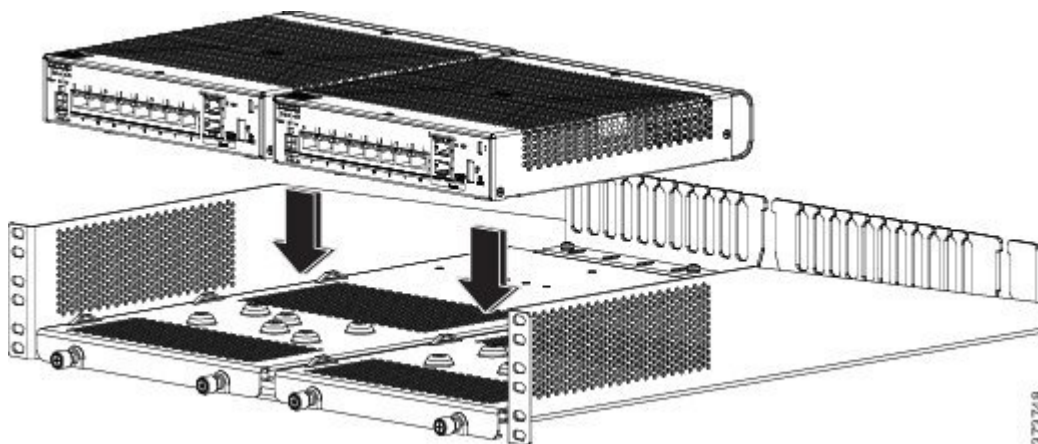
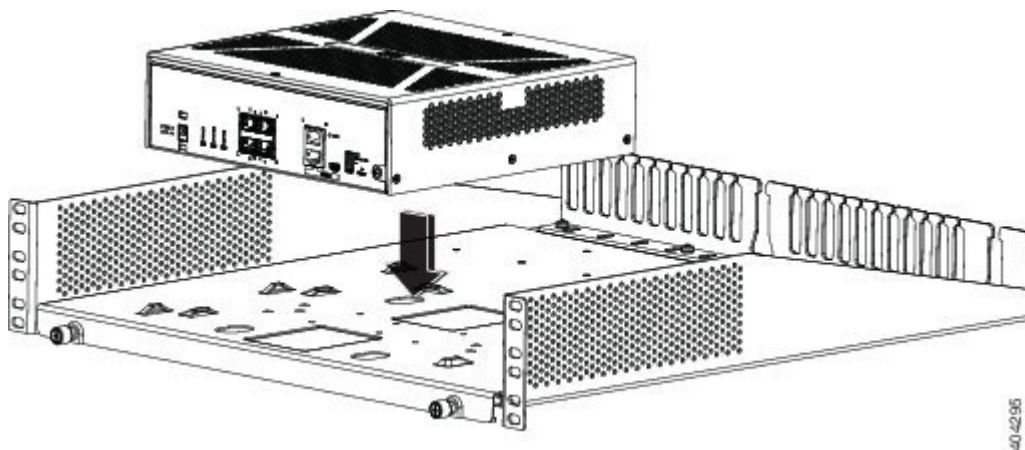

Figure 18: ASA 5506H-X in the Rack-Mount Shelf



- Step 5** Carefully turn the tray right-side up and slide it into the rack-mounted shelf.

What to Do Next

You can now install the cables and power cord, as described in [Connect Cables, Turn on Power, and Verify Connectivity](#), on page 37.

Install the ASA 5506H-X in a DIN Rail

You can use the 7.5-mm thick 45mm wide top hat DIN rail for the ASA 5506H-X. Secure the DIN rail to the mounting surface approximately every 7.8 inches (200 mm) and use end-anchors appropriately.



Note

We recommend that you install the ASA 5506H-X on a steel DIN rail for extra stability.

To attach the ASA 5506H-X to a 35-mm wide DIN rail, follow these steps:

Step 1 Attach the DIN rail bracket to the back of the chassis using the four screws provided.

Figure 19: Attaching the DIN Rail Bracket to the ASA 5506H-X

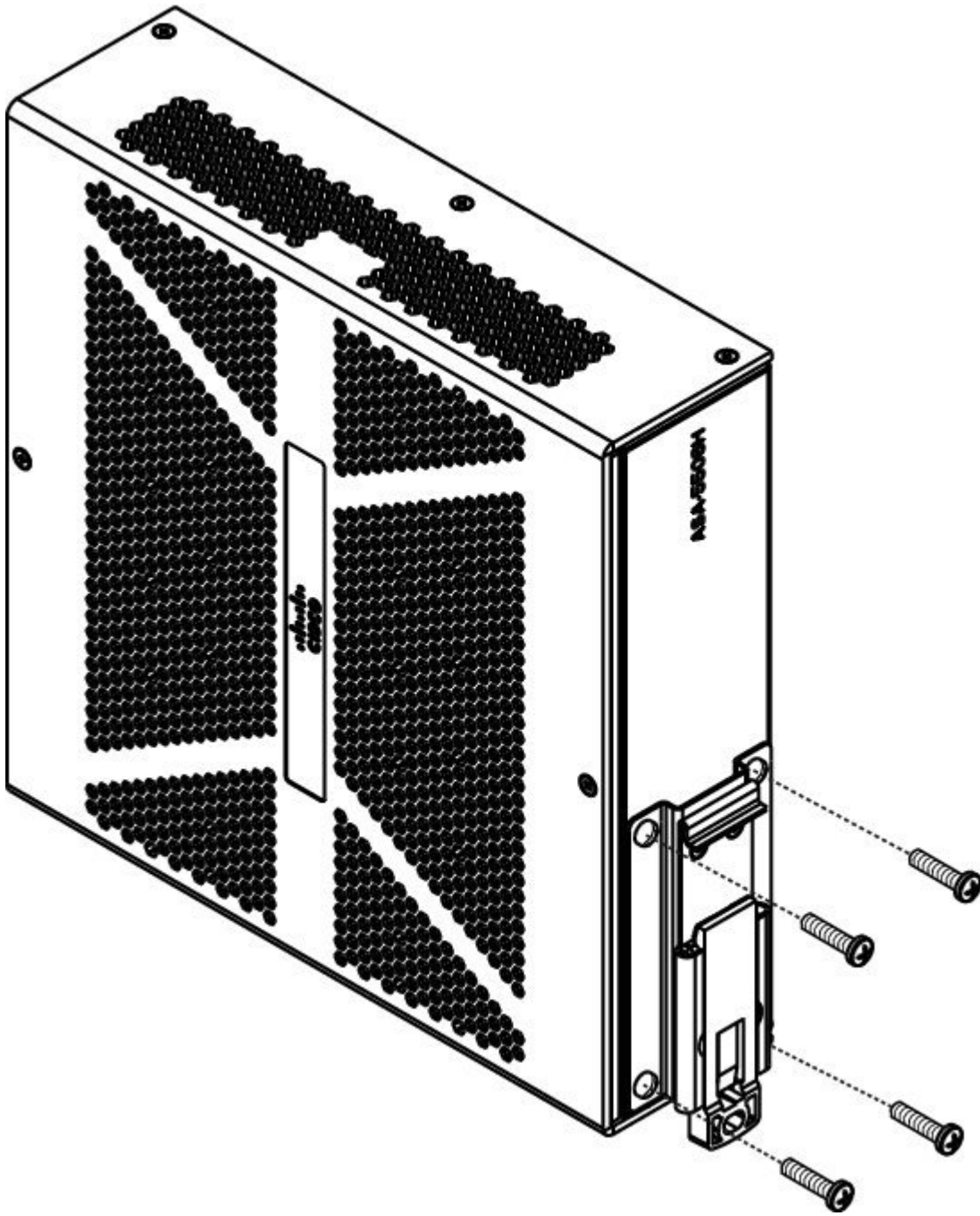

- Step 2** Locate the plastic tab on the end of the DIN rail bracket that extends past the chassis. Press the tab in and slide the plastic latch piece out while the tab is pressed down to put it into the locked position.
- Step 3** Turn the chassis sideways so that the power connector is near the top.
- Step 4** Position the rear edge of the chassis directly in front of the DIN rail making sure that the DIN rail fits in the space between the plastic latch and the metal hook.
- Step 5** Position the chassis so that the hook on the DIN rail bracket hooks onto the top edge of the DIN rail. The weight of the chassis can rest on the hook temporarily while the DIN rail bracket latches are secured.
- Step 6** Push the DIN rail bracket latch up when the chassis is over the DIN rail to secure it. This snaps the latch into the closed position which locks it onto the DIN rail.

Figure 20: ASA 5506H-X Installed with the DIN Rail

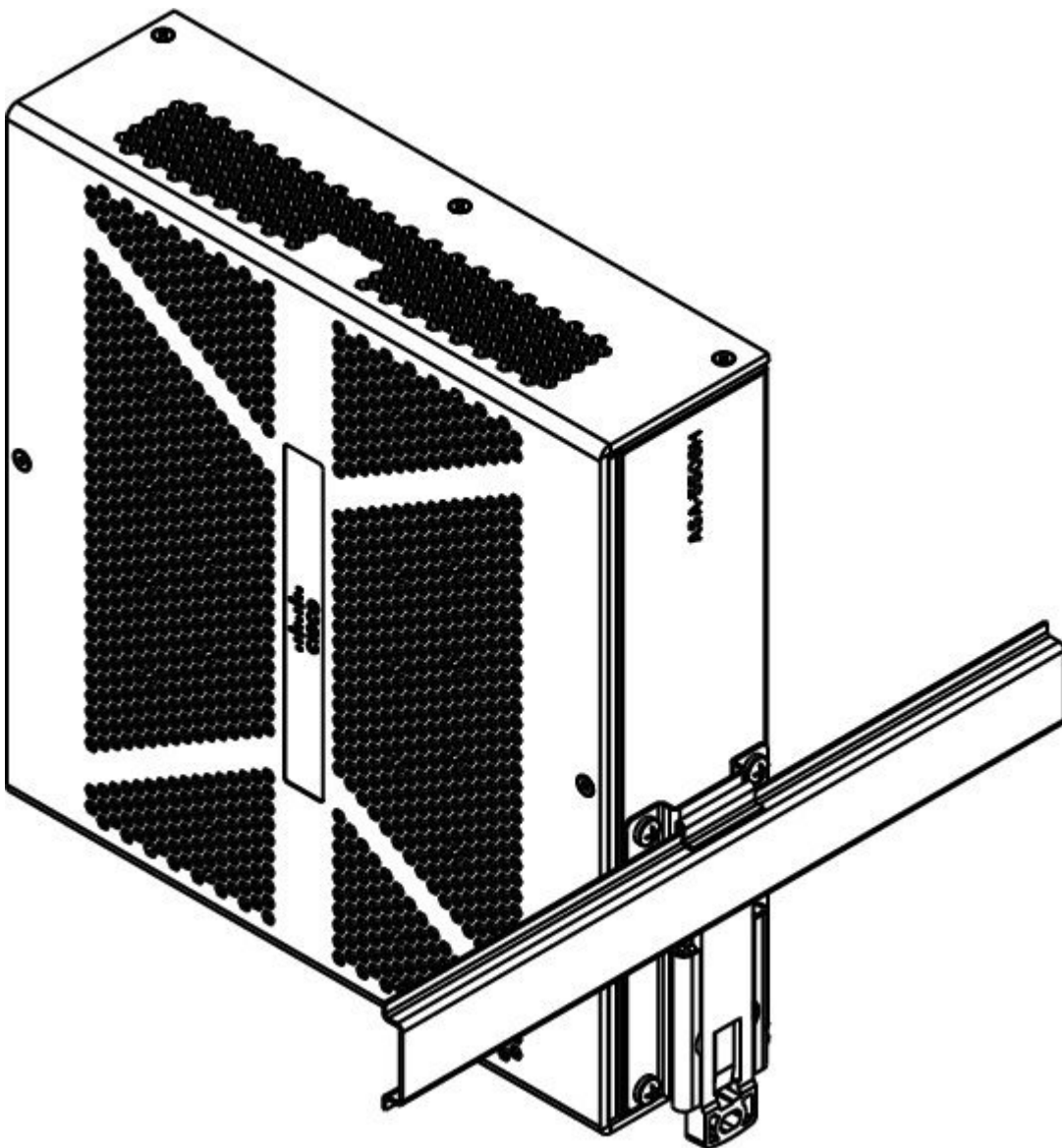

The chassis is now installed in the DIN rail.

What to Do Next

See [Connect Cables, Turn on Power, and Verify Connectivity](#), on page 37 to finish setting up your ASA.

Connect Cables, Turn on Power, and Verify Connectivity

After positioning or mounting the ASA, follow these steps to connect cables, turn on power, and verify connectivity:

Step 1

Connect the network cables:

- a) Management interface – Using this Management 1/1 Gigabit Ethernet port, you can connect a management computer directly with an Ethernet cable, or you can connect the computer and the ASA to the same management network. Be sure the PC is configured to obtain an IP address using DHCP. You can configure any of the Gigabit Ethernet interfaces to be a management-only interface using the **management-only** command. However, you cannot disable management-only mode on the Management 1/1 interface. The following figure shows how to connect the network cables.

Figure 21: ASA 5506-X and ASA 5506W-X Cabling

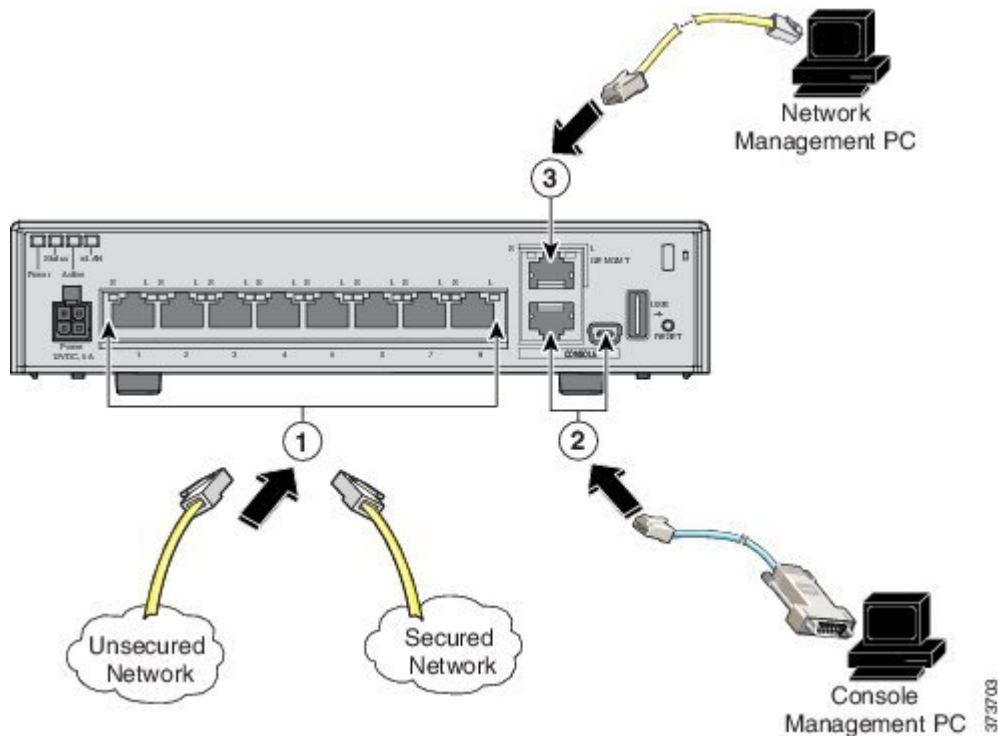

1	Gigabit Ethernet data interface (RJ-45)	2	Console port (RJ-45 or Mini USB Type B)
3	Management 1/1 interface (RJ-45)		

Figure 22: ASA 5506H-X Cabling

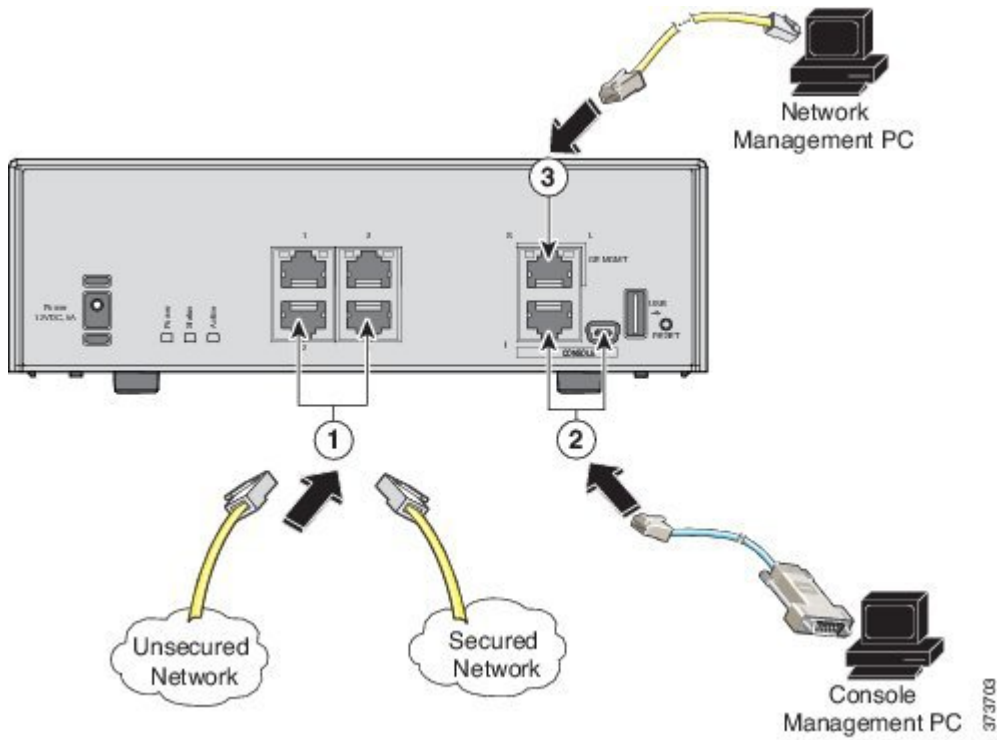

1	Gigabit Ethernet data interface (RJ-45)	2	Console port (RJ-45 or Mini USB Type B)
3	Management 1/1 interface (RJ-45)		

- b) (Optional) Console port – For use with the CLI. Connect a computer or terminal server using a serial console cable to either the RJ-45 or Mini USB Type B port. Only one console port can be active at a time. When a cable is plugged into the USB console port, the RJ-45 port becomes inactive. Conversely, when the USB cable is removed from the Mini USB Type B port, the RJ-45 port becomes active. See [Connect to a Console Terminal or PC, on page 39](#) for specific instructions for connecting the console port.
- c) Gigabit Ethernet ports – For the network interfaces; use standard RJ-45 Ethernet cables.

Step 2

Connect the power cord to the ASA, and plug the other end to your power source.

Note The ASA 5506-X, 5506W-X, and ASA 5506H-X do not have an on/off switch; the device powers on when you plug it into a power source.

- Step 3** Check the Status LED on the ASA chassis.
When it is solid green, the ASA has passed power-on diagnostics.
-

What to Do Next

You can now proceed to configuration of the ASA, as described in the [Quick Start Guide](#).

Connect to a Console Terminal or PC

The serial ports provide administrative access to the ASA either with a console terminal or a PC. To configure the ASA through the CLI, you must establish a connection between the ASA console port and either a terminal or a PC.

This section describes how to connect to a console terminal or a PC, and contains the following topics:

Connect to the Console Port with Microsoft Windows

You must install a USB device driver the first time a Microsoft Windows-based PC is connected to the USB serial port on the ASA, otherwise the connection fails.

To uninstall the driver, use the Add Remove Programs utility or the Setup-exe program.



Note Disconnect the ASA console terminal before uninstalling the driver.

- Step 1** Obtain the appropriate driver (Cisco_usbconsole_driver_X_X_zip, where X is a revision number) for your ASA model from the Cisco [Download Software](#) site, USB Console Software category.
- Step 2** Install the driver.
- Step 3** Connect a USB 5-pin Mini USB Type B to the USB console port as shown in the following figure.

Figure 23: ASA 5506-X and ASA 5506W-X Console Port Connection

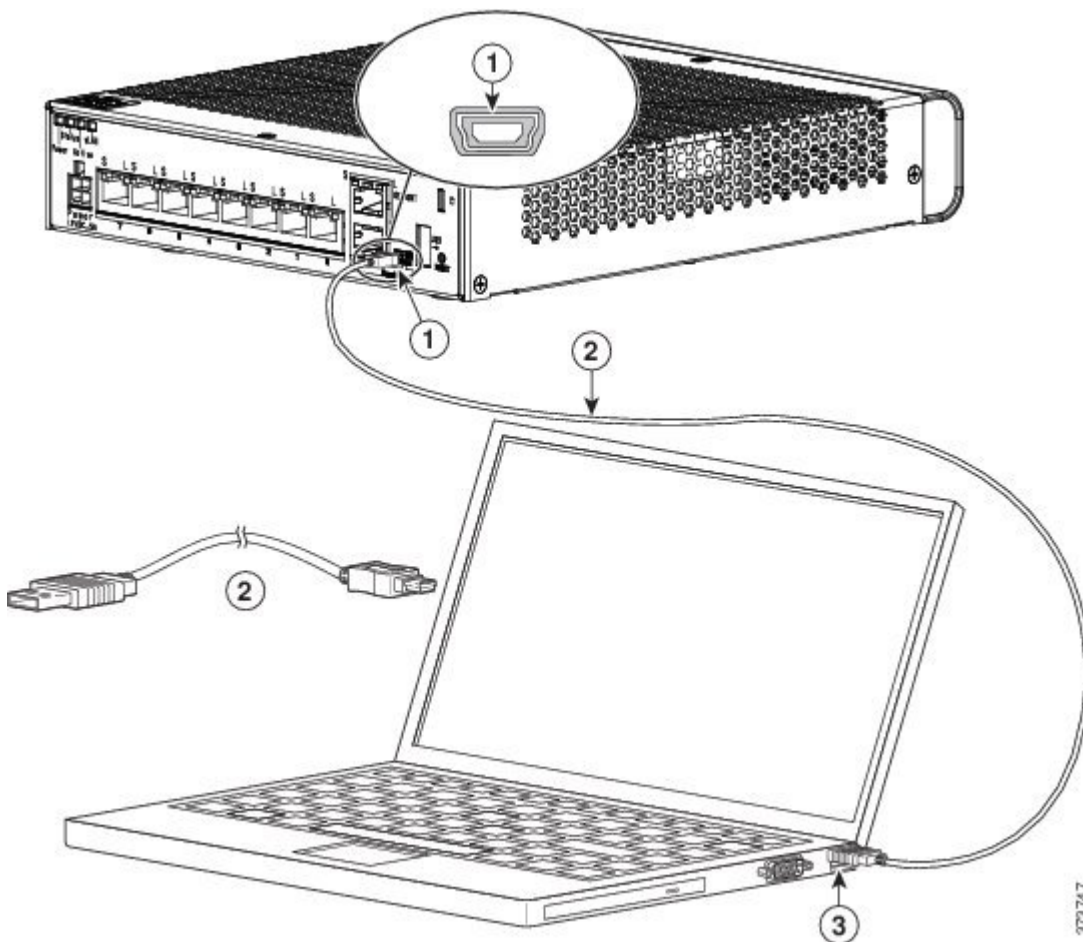

1	Mini USB Type B console port	2	Mini USB Type B to USB Type A console cable
3	USB Type A		

Figure 24: ASA 5506H-X Console Port Connection

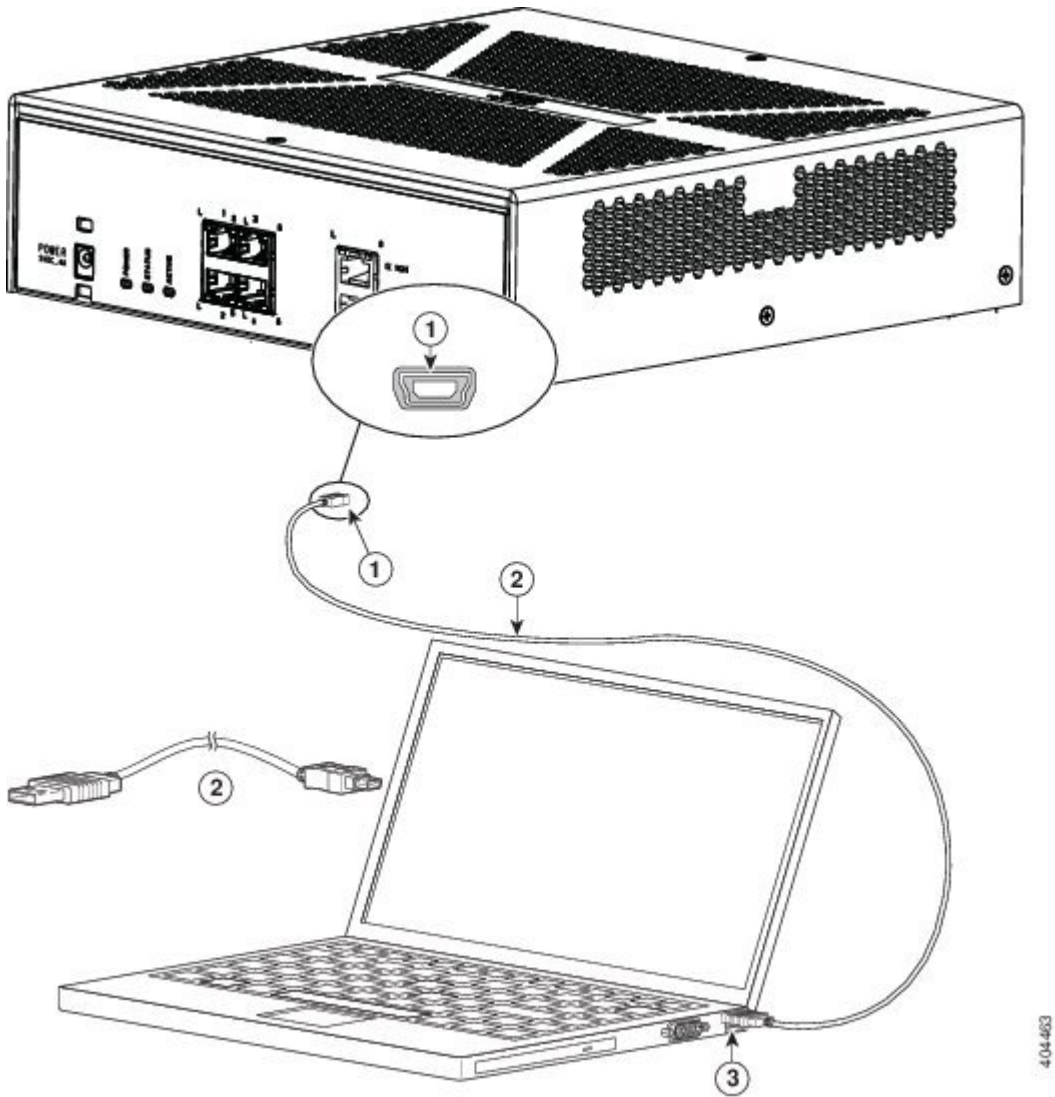

1	Mini USB Type B console port	2	Mini USB Type B to USB Type A console cable
3	USB Type A		

Step 4 Connect the end of the cable with the DB-9 connector (or USB Type A) to the terminal or PC. If your terminal or PC has a console port that does not accommodate a DB-9 connector, you must provide an appropriate adapter for that port.

The LED for the console port turns green and within a few moments the Found New Hardware Wizard appears.

Step 5 Follow the instructions to complete the driver installation.

Step 6 To communicate with the ASA, start a terminal emulator application. This software should be configured with the following parameters:

- 9600 baud
- 8 data bits
- no parity
- 1 stop bit
- no flow control

Connect to the Console Port with Mac OS X

Follow these steps to connect a Mac OS X system USB port to the console using the built in OS X Terminal utility, or alternatively you can use a separate terminal emulator application.

Step 1 Use the Finder to go to **Applications > Utilities > Terminal**.

Step 2 Connect the OS X USB port to the ASA.

Step 3 Enter the following commands to find the OS X USB port number:

Example:

```
macbook:user$ cd /dev
macbook:user$ ls -ltr /dev/*usb*
crw-rw-rw- 1 root wheel 9, 66 Apr 1 16:46 tty.usbmodem1a21
DT-macbook:dev user$
```

Step 4 Connect to the USB port with the following command followed by the ASA USB port speed:

Example:

```
macbook:user$ screen /dev/tty.usbmodem1a21 9600
```

Step 5 Enter **Ctrl-z** followed by **Ctrl-** to disconnect the OS X USB console from the Terminal window.

Connect to the Console Port with Linux

Follow these steps to connect a Linux system USB port to the console using the built-in Linux Terminal utility.

Step 1 Open the Linux Terminal window.

Step 2 Connect the Linux USB port to the ASA.

Step 3 Enter the following commands to find the Linux USB port number:

Example:

```
root@usb-suse# cd /dev
root@usb-suse /dev# ls -ltr *ACM*
crw-r--r-- 1 root root 188, 0 Jan 14 18:02 ttyACM0
root@usb-suse /dev#
```

Step 4 Connect to the USB port with the following command followed by the ASA USB port speed

Example:

```
root@usb-suse /dev# screen /dev/ttyACM0 9600
```

Step 5 To disconnect the Linux USB console from the Terminal window, enter **Ctrl-a** followed by **:** then **quit**.
