



Polycom® HDX 9000™ Series

Premier Video Conferencing Systems for High Impact Visual Experiences



Benefits

High definition video – Natural communications in 1280 x 720 at 30fps (720p), with exceptional resolution even at lower data rates

High definition voice – Polycom's Siren 22 along with Polycom's StereoSurround offers audio performance that is superior in today's marketplace

High definition content – Share graphics, presentations, and rich media content with HD and non-HD systems with use of People+Content™, People+Content IP and People On Content™ collaboration technologies

Flexible integration – A 2U design, flexible audio video and audio inputs and outputs for integration into many types of rooms and environments

Simplified integration – Easily integrate with Polycom's SoundStructure™ installed audio systems and AMX® or Crestron® control devices for complete system control

Embedded multipoint – An optional 4 or 8 way embedded multipoint bridge allows for greater flexibility for your larger conferences

Flexible connectivity – Optional network interfaces allow for easy access to your BRI, PRI or V.35 network

Key element of a total Polycom video solution – Seamlessly integrates with the Polycom RMX 2000™ conference bridge, Video Media Center™ 1000 solution, RSS™ 2000 recording and streaming server, and ReadiManager® SE 200 management and scheduling application

Polycom HDX 9000 Series video conferencing systems deliver high definition collaboration experiences in conference rooms, lecture halls, executive suites and more.

The HDX 9000 systems' intuitive user interfaces are bolstered by high-performance architectures that radically boost video conference quality and allows attendees to interact and communicate naturally.

The HDX 9000 series systems powerfully and seamlessly integrate with rich media tools to enhance any presentation or meeting environment. Through integration of the Polycom HDX 9000 system's powerful set of APIs and abundant video and audio connectors, customers can create and customize conferencing solutions for simple to advanced applications, including auditoriums utilizing multiple cameras, projectors and displays, executive boardrooms with touch-panel displays, recessed lighting and individual participant monitors, and training facilities with high definition lecture recording systems and HD document cameras

Life-like conference audio for HDX 9000 system environments is driven by Polycom Siren™ 22 and Polycom StereoSurround™ technologies, enabling attendees to hear remote participants' voices in stereo through left and right dual-mode speakers within a single microphone array. The HDX 9000 system is powerful enough to discern the most subtle of sounds and transmit them to others in the conference, enabling clearer and less ambiguous communications and more efficient meetings.

Make Great Things Happen with the Polycom HDX 9000 Series

In today's Internet driven world, the ability to conduct real time communication and collaboration has become critical to an organization's survival. As the market leader in voice, video, data and Web solutions, our award-winning conference technology makes it easy for people to interact and maximize productivity – over any network, in just about any environment, anywhere around the globe. That's why more organizations worldwide use and prefer Polycom conferencing solutions. Because when people work together, great things happen. See how you, too, can achieve great things with the Polycom HDX 9000 series.

Polycom HDX 9000 Series

Video Standards & Protocols

- H.261
- H.263++
- H.264
- People+Content / H.239
- H.263 & H.264 Video Error Concealment

People Video Resolution

- 720p, 30fps at 1Mbps–4Mbps
- 4SIF (704 x 480)/4CIF (704 x 576) at 256Kbps–1Mbps
- SIF (352 x 240), CIF (352 x 288)
- QSIF (176 x 120), QCIF (176 x 144)
- Choice of native 4:3 or 16:9 display aspect ratios

Content Video Resolution

- Up to 720p
- Input: SXGA (1280x1024) (9004), HD (1280x720), XGA (1024 x 768), SVGA (800 x 600), VGA (640 x 480)
- Output: XGA (1024x768), SVGA (800x600), SXGA 1280x1024 (9004), HD 1280x720

Audio Standards & Protocols

- Polycom StereoSurround
- 22kHz bandwidth with Polycom Siren 22
- 14kHz bandwidth with Polycom Siren 14 , G.722.1 Annex C
- 7 kHz bandwidth with G.722, G.722.1
- 3.4 kHz bandwidth with G.711, G.728, G.729A
- Automatic Gain Control
- Automatic Noise Suppression
- Instant Adaptation Echo Cancellation
- Audio Error Concealment
- Keyboard Noise Reduction
- Music Mode
- Discussion Mode Stereo Audio (with MPPlus option)

Other ITU-Supported Standards

- H.221 communications
- H.224/H.281 far-end camera control
- H.323 Annex Q far-end camera control
- H.225, H.245, H.241, H.331
- H.239 dual stream
- H.231 in multipoint calls
- H.243 chair control
- H.460 NAT/firewall traversal
- BONDING, Mode 1

Network

- Interfaces
 - 10/100/1000 auto NIC, RJ45 connector
 - RJ11 analog phone connector
- H.323 up to 4 Mbps pt-to-pt, 8 Mbps total with MPPlus (9004)
- SIP up to 4 Mbps
- IPv6 support
- H.320
 - ISDN Quad BRI
 - ISDN PRI T1 or E1
 - Serial (RS449, V.35, RS 530) up to 2 Mbps
- iPriority™ for QoS
- Lost Packet Recovery (LPR)
- Dynamic Bandwidth Allocation (DBA)
- Reconfigurable MTU size
- Auto SPID detection and line number configuration

User Interface

- Directory Services
- System Management
 - Web-based
 - SNMP
 - Global Management System™
- CDR
- API support

- International languages (17)
- RSS 2000 integration with HDX remote control
- USB Software Update

Security

- Secure Web
- Secure Telnet
- Security Mode
- Embedded AES FIPS 197, H.235V3 and H.233/234
- Secure password authentication

Options

- Polycom EagleEye™ HD Camera
 - 1280 x 720p CCD imager
 - 12X optical zoom
 - 72deg FOV at min zoom
 - +/- 100 deg pan range
 - +/-20/-30 deg tilt range
 - Output formats: SMPTE 296M 1280 x 720p, 50/60 FPS
 - Component, YPbPr output
- Avaya Network Connectivity
- People On Content
- MPPlus software for up to 4 (all models) or 8 (9004) sites
 - Audio transcoding
 - Video transcoding (line rate & speed)
 - StereoSurround and Siren 22 audio
 - Dual monitor emulation
 - People+Content supported
 - Voice activated switching
 - High Definition in continuous presence mode
- HDX Microphone Array
- Ceiling Microphone Array
- SoundStructure™ Integration
- Upgrade to 8 Mbps line rate (to be used only with internal MCU on 9004)

Electrical

- Auto sensing power supply
- Typical operating voltage/power 189VA @ 115V @ 60 Hz @ .67 PF
- Typical operating voltage/power 192VA @ 230V @ 60 Hz @ .66 PF
- Typical operating voltage/power 196VA @ 230V @ 50 Hz @ .65 PF

These numbers were empirically collected under TYPICAL operating conditions. No attempt was made to force max power consumption. Voltages and currents are RMS. Power units are Volt-Amp.

Environmental Specification

- Operating Temperature: 0-40oC
- Operating Humidity: 10-80%
- Non-Operating Temperature: -40 o -70o C
- Non-Operating Humidity (Non-condensing): 10-90%
- Maximum altitude is 10,000 feet

Physical Characteristics

- Video Base Unit (W/H/D): 17.2"x3.44"x14.5"; 436.88 mm / 87.38 mm / 368.3 mm
- Video Base Unit Weight: 20.5 lbs; 9.3 kg

Warranty

- One-year return to factory parts and labor
- 90-day software warranty

Technical Documentation

- Award-winning documentation for setting up, maintaining, and using the system
- Available at www.polycom.com/videoeducation

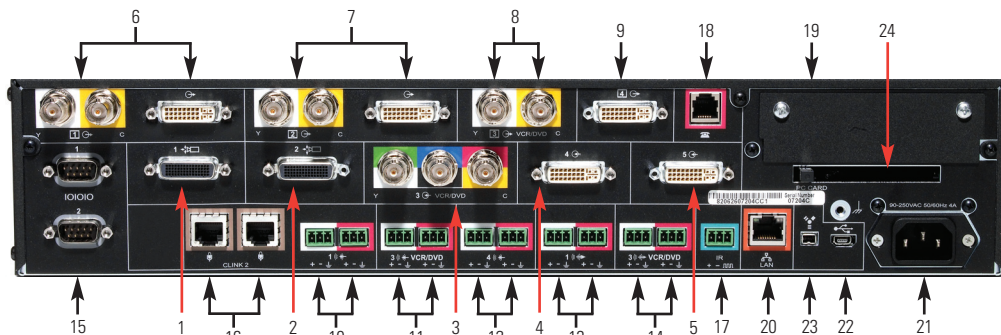

- | | | |
|--|--|---|
| <ol style="list-style-type: none"> 1. Video input 1: HDCI (Composite, S-Video, YPbPr, DVI) 2. Video input 2: HDCI (Composite, S-Video, YPbPr, DVI) 3. Video input 3: 3-BNC (9004) (Composite, S-Video, YPbPr) 2-BNC (9001 & 9002) (Composite, S-Video) 4. Video input 4: DVI-I (VGA, DVI) 5. Video input 5: (9004) DVI-I (VGA, DVI) 6. Video output 1: 2-BNC (S-Video, Composite) DVI-I (VGA, DVI, YPbPr) 7. Video output 2: 2-BNC (S-Video, Composite) DVI-I (VGA, DVI, YPbPr) | <ol style="list-style-type: none"> 8. Video output 3: 2-BNC (S-Video, Composite) 9. Video output 4: (9004) DVI-I (VGA, DVI, YPbPr) 10. Audio input 1: Phoenix, stereo (main audio) 11. Audio input 2: Phoenix, stereo (VCR audio, assoc with video input 3) 12. Audio input 3: (9004) Phoenix, stereo (PC audio, assoc with video input 4) 13. Audio output 1: Phoenix, stereo (main audio) 14. Audio output 2: Phoenix, stereo (VCR audio) 15. RS-232 ports for control (Dual ports on 9004 / Single port on 9001 & 9002) | <ol style="list-style-type: none"> 16. Connectors for HDX Microphone Arrays (up to 4 microphones total) 17. IR receiver 18. POTS phone connection 19. H.320 network interface bay 20. LAN/NIC, 10/100/1000 auto sensing 21. EIA electrical input 22. USB port (inactive) 23. 1394 Firewire (inactive) 24. PCMCIA slot (inactive) |
|--|--|---|

